

Evaluation of power deposition in HL-LHC with crystal-assisted heavy ion collimation



11th October 2023

V.Rodin, R.Bruce, R. Cai, M. D'Andrea, L. Esposito, A. Lechner,
D. Mirarchi, J.B. Potoine, S. Redaelli, P. Schoofs

Main goal and content

LHC betatron halo collimation system was designed to prevent magnet quenches during periods of reduced **beam lifetime**. Lead ions are subject to electromagnetic dissociation (**EMD**) and **inelastic scattering** in collimators producing many secondary fragments, which can leak into the adjacent dispersion suppressors (**DS**).

This year LHC began ion operation with **HL-LHC** settings, for this reason, a better understanding of the quench margin in these DS magnets is needed, considering the increased beam current and the resulting higher beam losses of up to a few tens of kW.

CDS, Image by M.
Brice

- Introduction: LHC collimation system and detection of losses
- Simulation workflow
- Investigation of power deposition in DS with FLUKA simulations:
- Comparison with previous studies

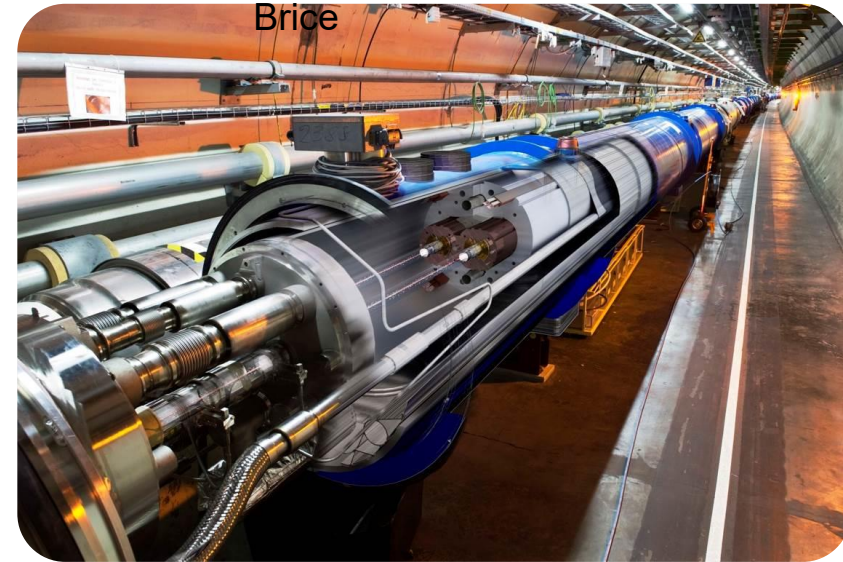

Introduction: LHC collimation system

Collimation system need to withstand effects of power deposition during nominal machine operation but also in case of abnormal (fast) beam losses. Power deposition in collimators is calculated using simulation tools and it provides insight into consequences of design or beam optics changes

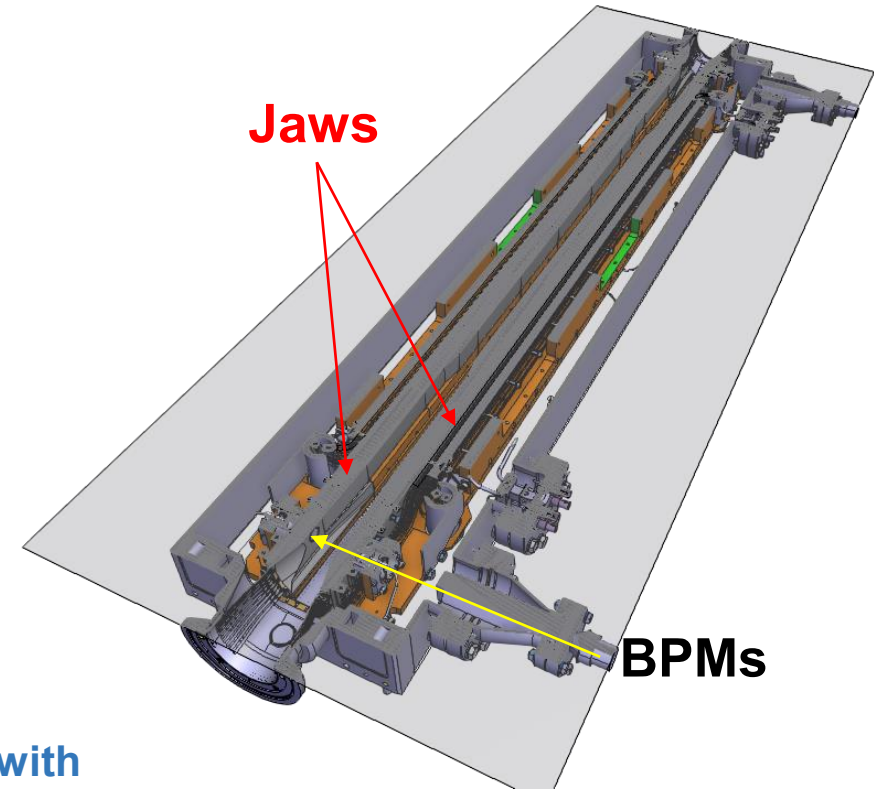
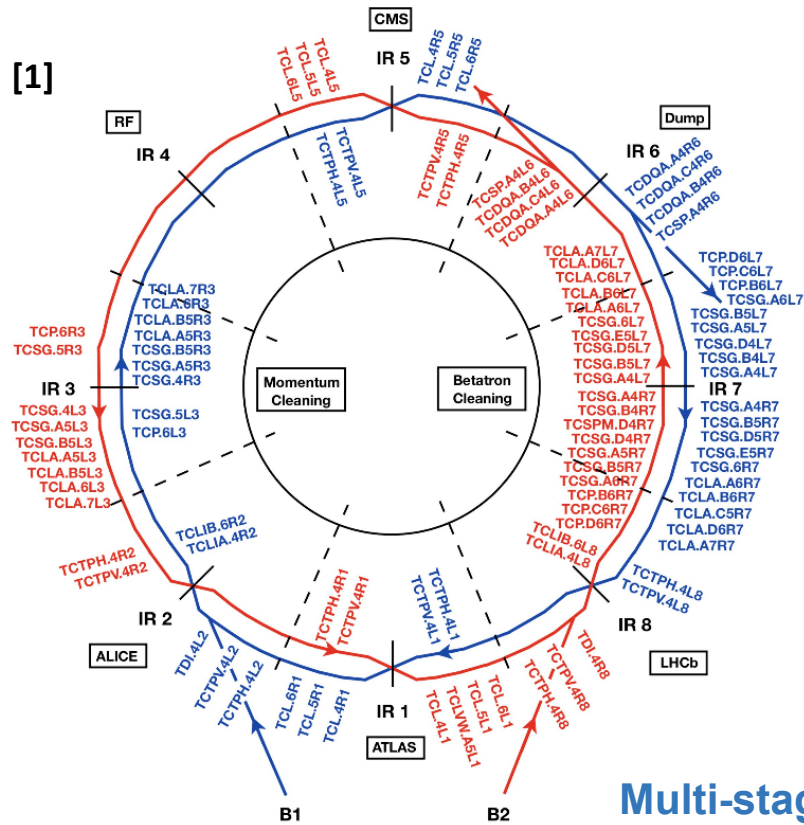

Multi-stage system with ~50 collimators per beam

[1] Data-driven cross-talk modeling of beam losses in LHC collimators, (G. Azzopardi)

Standard collimation system in LHC

Stored energy in the machine for protons: [1]

- LHC design: 360 MJ → 400 MJ (present)
→ 700 MJ (HL conditions)

Superconducting magnets (T = 1.9 K)

- quench limit ~ 15-50mJ/cm³

Collimation system is needed!

$\eta = 10^{-4}$ is the actual performance in LHC

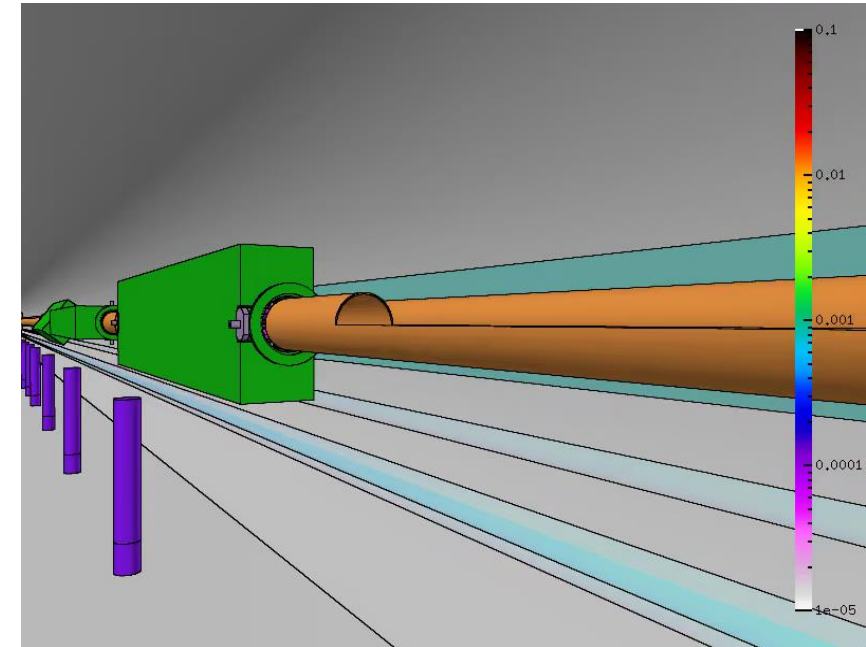
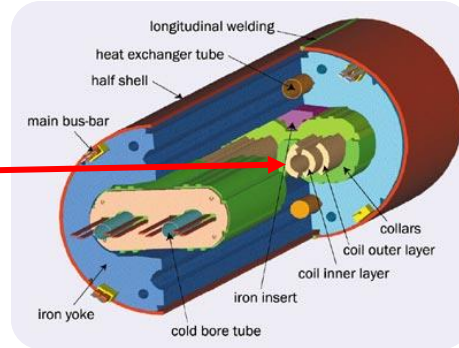

[2]

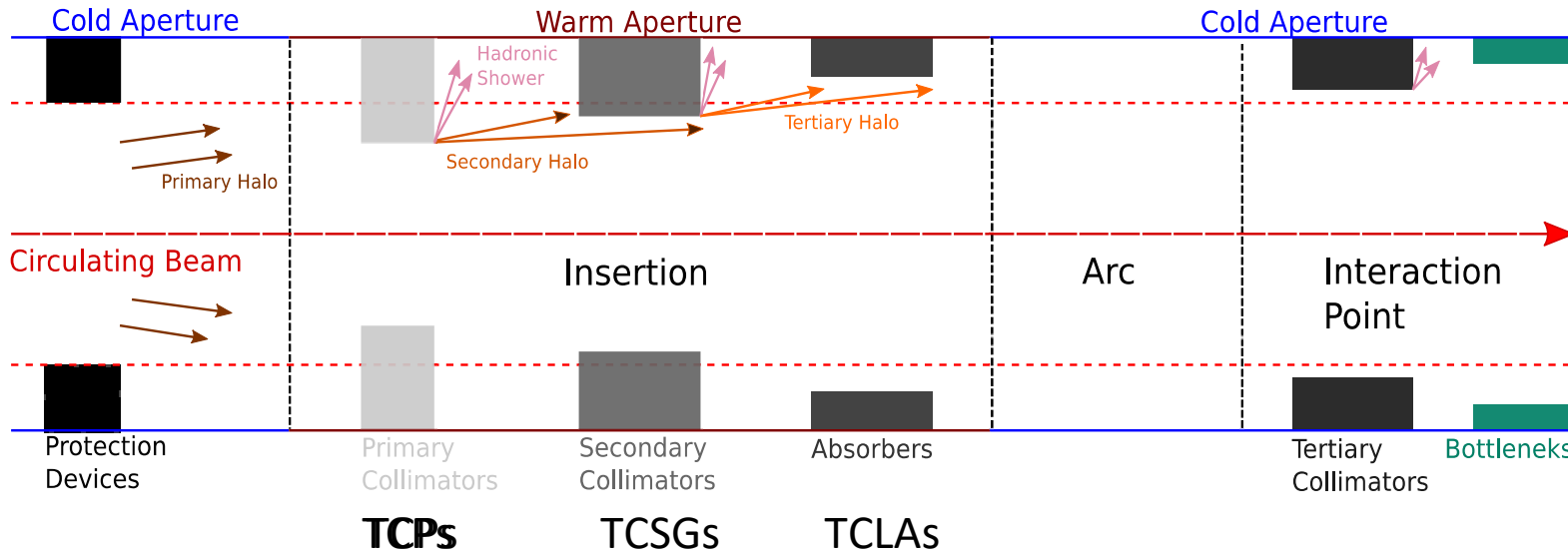

System tasks

- **Halo cleaning:** Reduction of the risk of magnet quenches
- **Concentration of losses/activation in controlled areas**

The cleaning efficiency with ions drops to 10⁻²!

[1] LHC dipole production begins to take off
CERN Courier

[2] Beam Cleaning and Collimation Systems
(S. Redaelli)

Crystal assisted collimation system in LHC Run 3

Stored energy in the machine for ions:

- HL-LHC design: 20 MJ

Beam energy:

- 6.37 ZTeV → 6.8 ZTeV

Expected that the maximum allowed power loss without quenching is 35-60 kW

Collimation system with crystal as baseline for HL-LHC

- Single side jaw collimation in horizontal and vertical plane of each beam

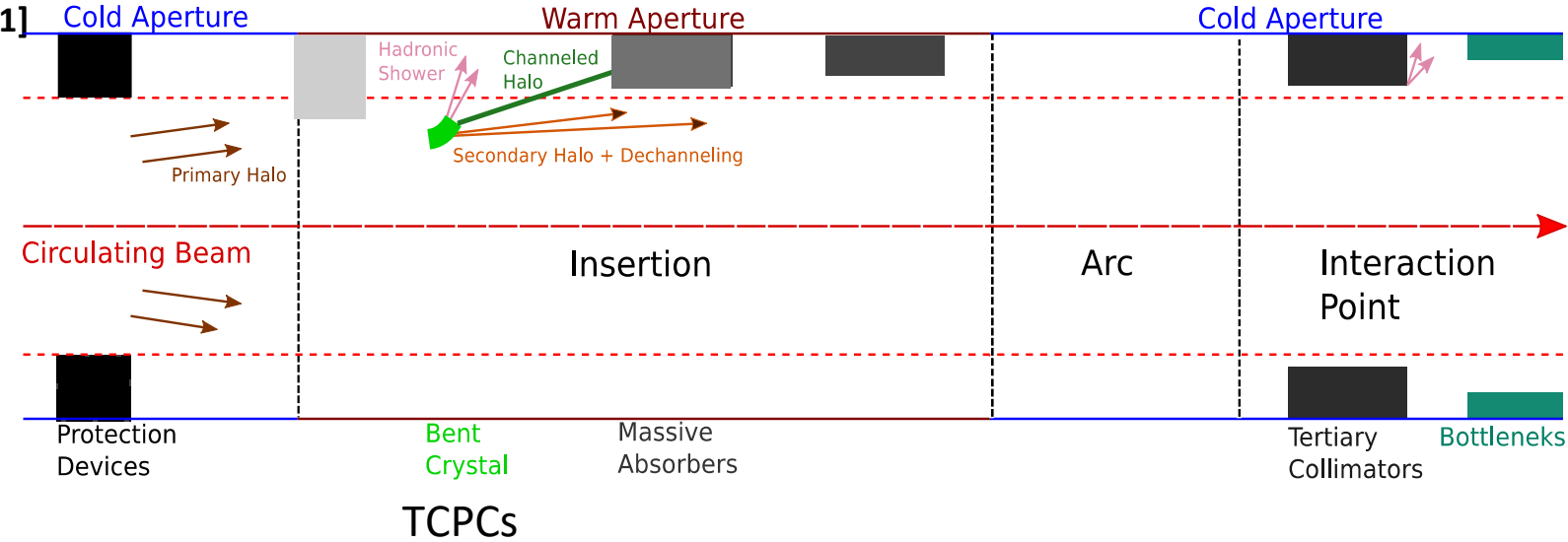
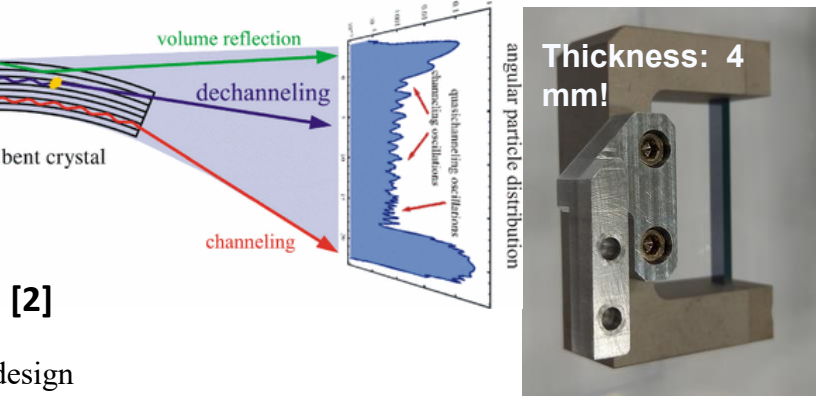
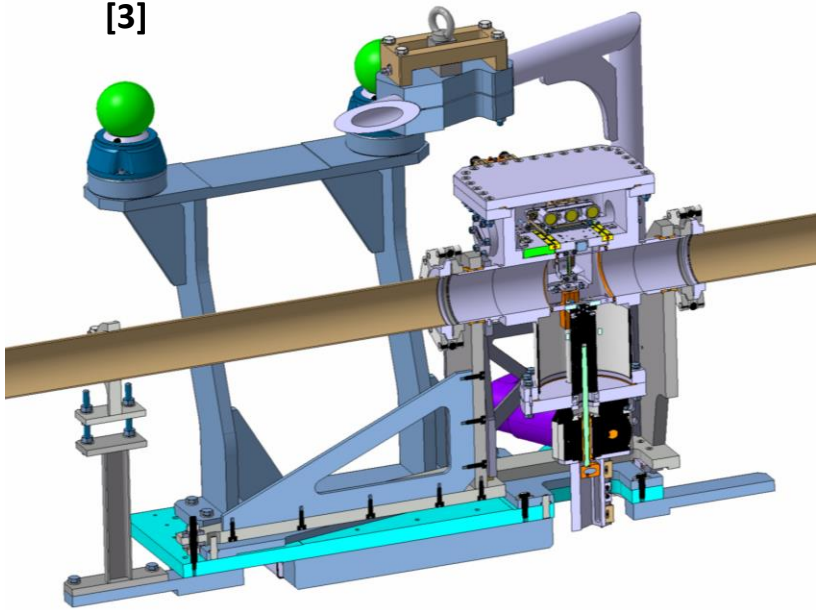

[1] Beam Cleaning and Collimation Systems (S. Redaelli)

[2] Planar channeling and quasicchanneling oscillations in a bent crystal (A. Sytov)

[3] LHC Crystal collimator design (I.L. Garcia)

Crystal Channeling: Main concepts

[1]

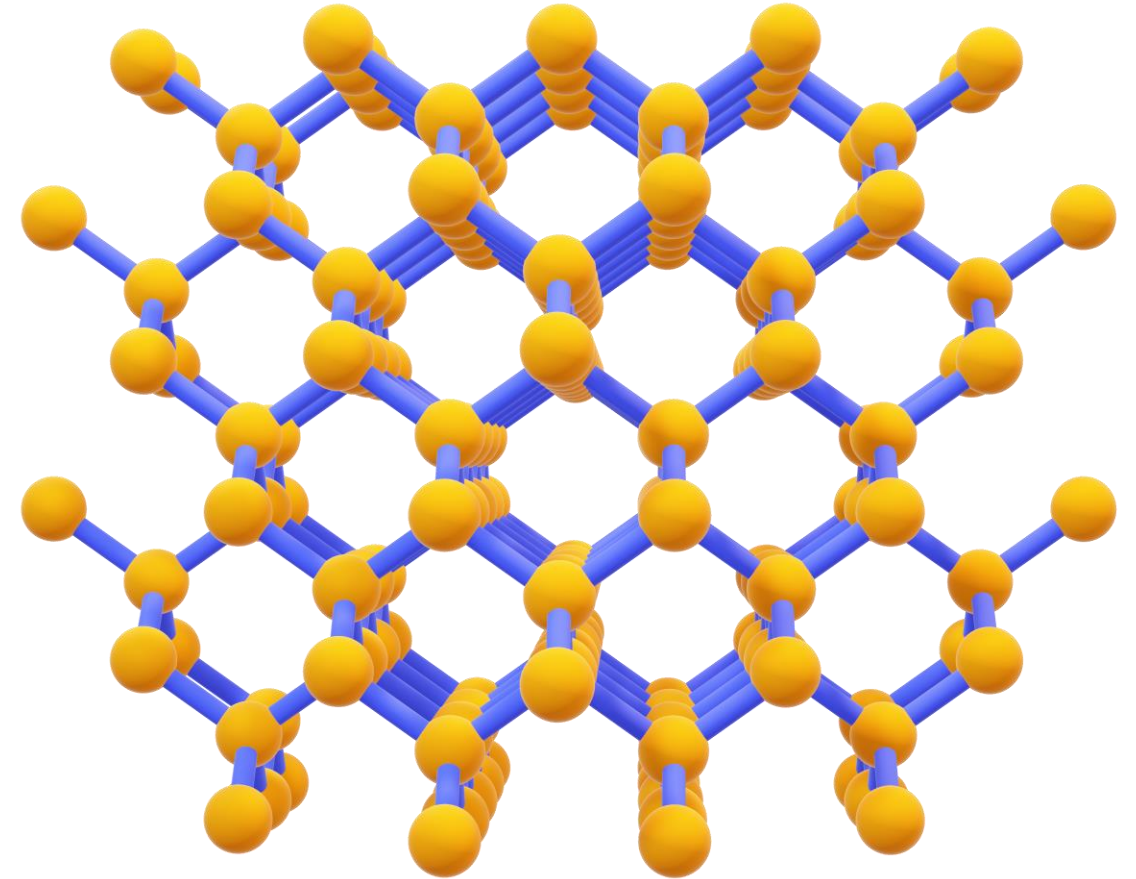
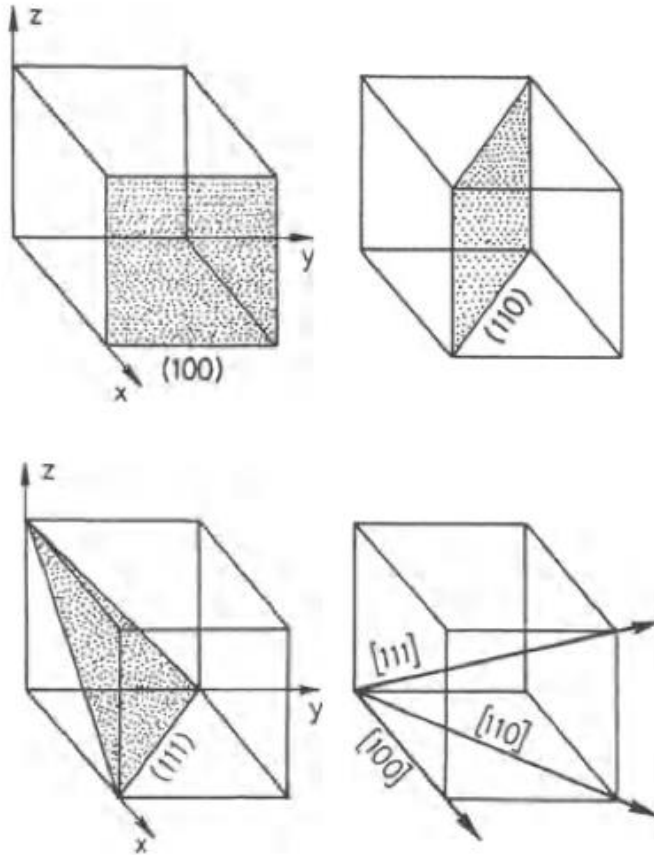

Diamond Crystal structure (C, Si, Ge, W)

Miller indices:

- Lattice planes (110) and (111) are most efficient

[1] Crystal Channeling and Its Application at High-Energy Accelerators (V.M. Biryukov)

Crystal Planar Channeling

Channeling condition is defined from the particle transverse momentum and the electrostatic potential generated by the atoms of the crystalline structure

Critical angle

$$\theta_c = \sqrt{\frac{2U_{max}}{pv}}$$

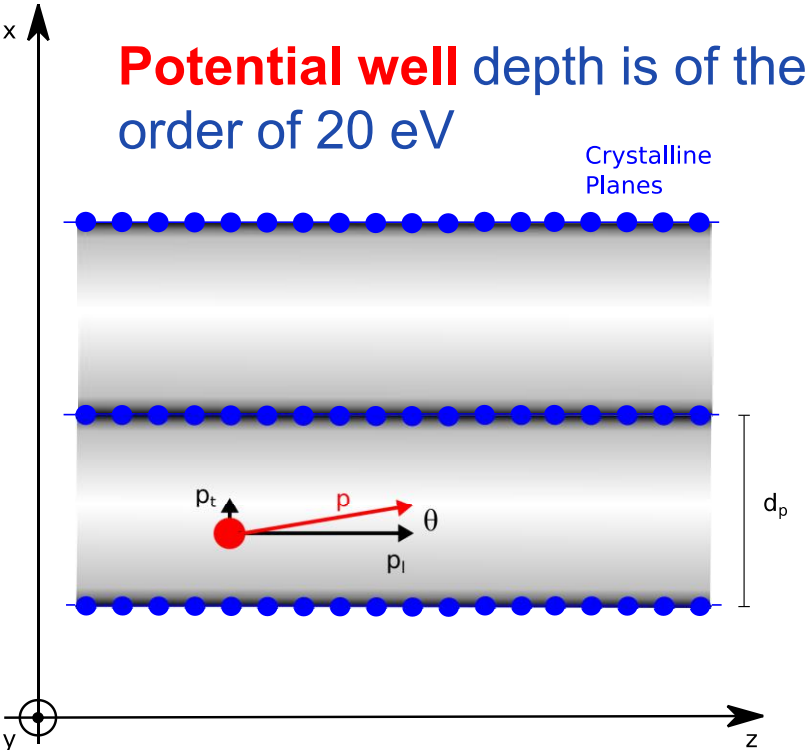
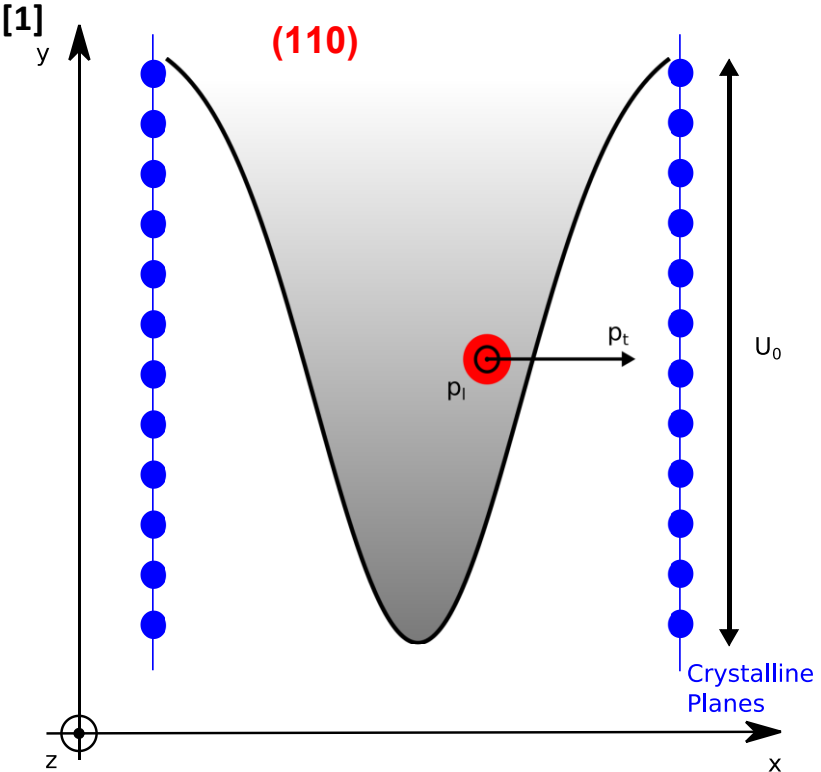
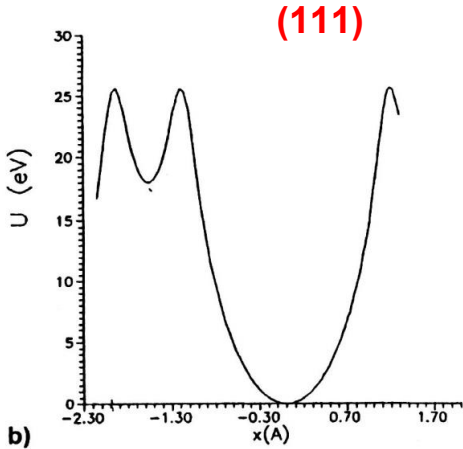

Energy	θ_c
500 MeV	282.8 μ rad
120 GeV	18.3 μ rad
180 GeV	18.0 μ rad
270 GeV	12.2 μ rad
400 GeV	10.0 μ rad
450 GeV	9.4 μ rad
6.5 TeV	2.5 μ rad
7 TeV	2.4 μ rad
50 TeV	0.9 μ rad

[1] Experimental Assessment of Crystal Collimation at the Large Hadron Collider (R. Rossi)

Channeling in Bent Crystals

The particles are trapped in a channel, hence if a curvature is given to the lattice the particles direction will be modified by $\theta_b = l/R$

The bending induces a centrifugal term that deforms the straight potential with an additional term depending on both the crystal curvature and the particles energy:

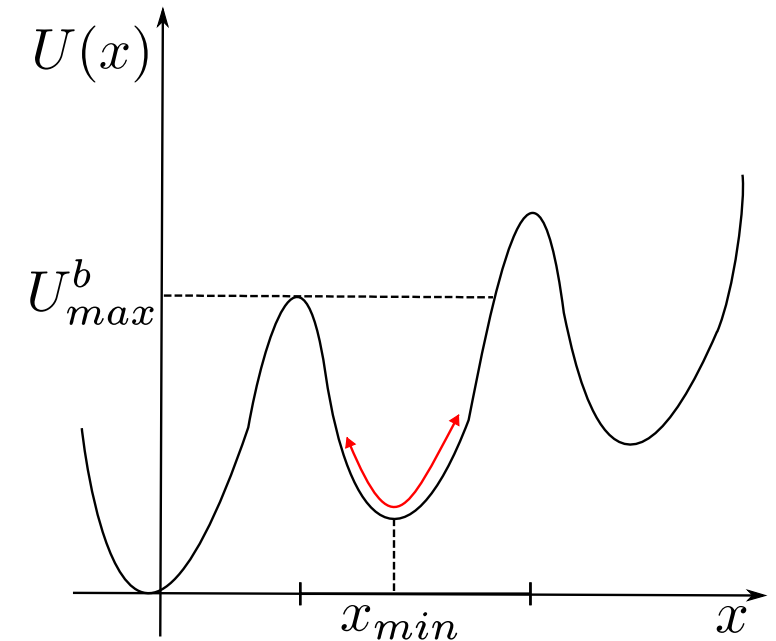
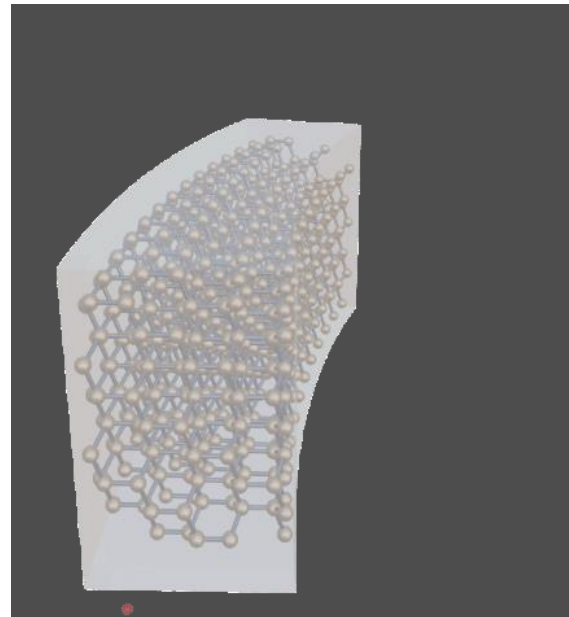
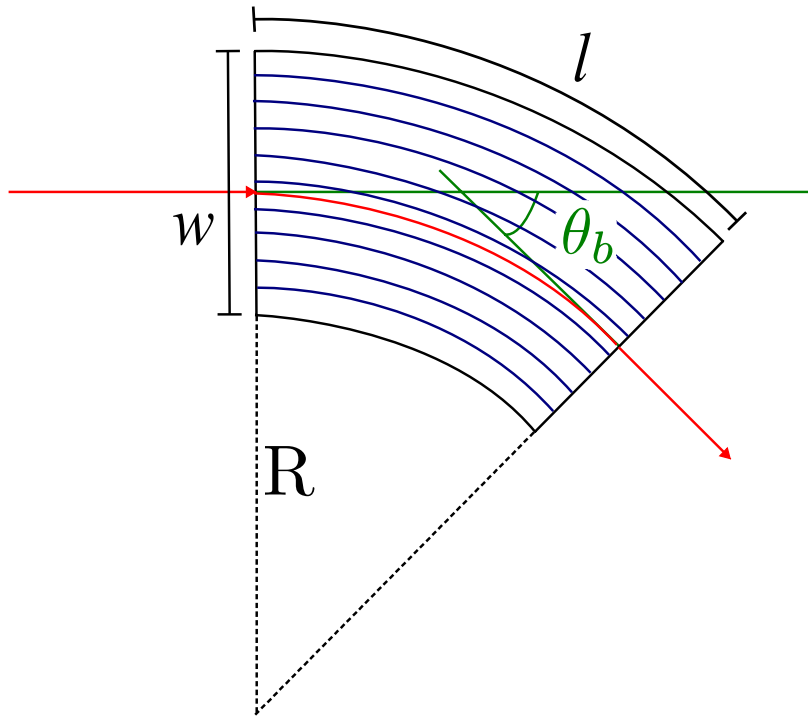

Beam manipulation with bent crystal

Two coherent effects could be used for beam deflection in particle accelerators:

- Channeling \rightarrow (CH) larger deflection with smaller efficiency and smaller angular acceptance
- Volume Reflection (VR) \rightarrow smaller deflection with larger efficiency and larger angular acceptance

Several other effects are present

- Volume Capture (VC) \rightarrow capture downstream the crystal and partial deflection with small probability
- Dechanneling (DCH) \rightarrow lose of channeling conditions downstream the crystal due to inelastic interaction
- And transitions...

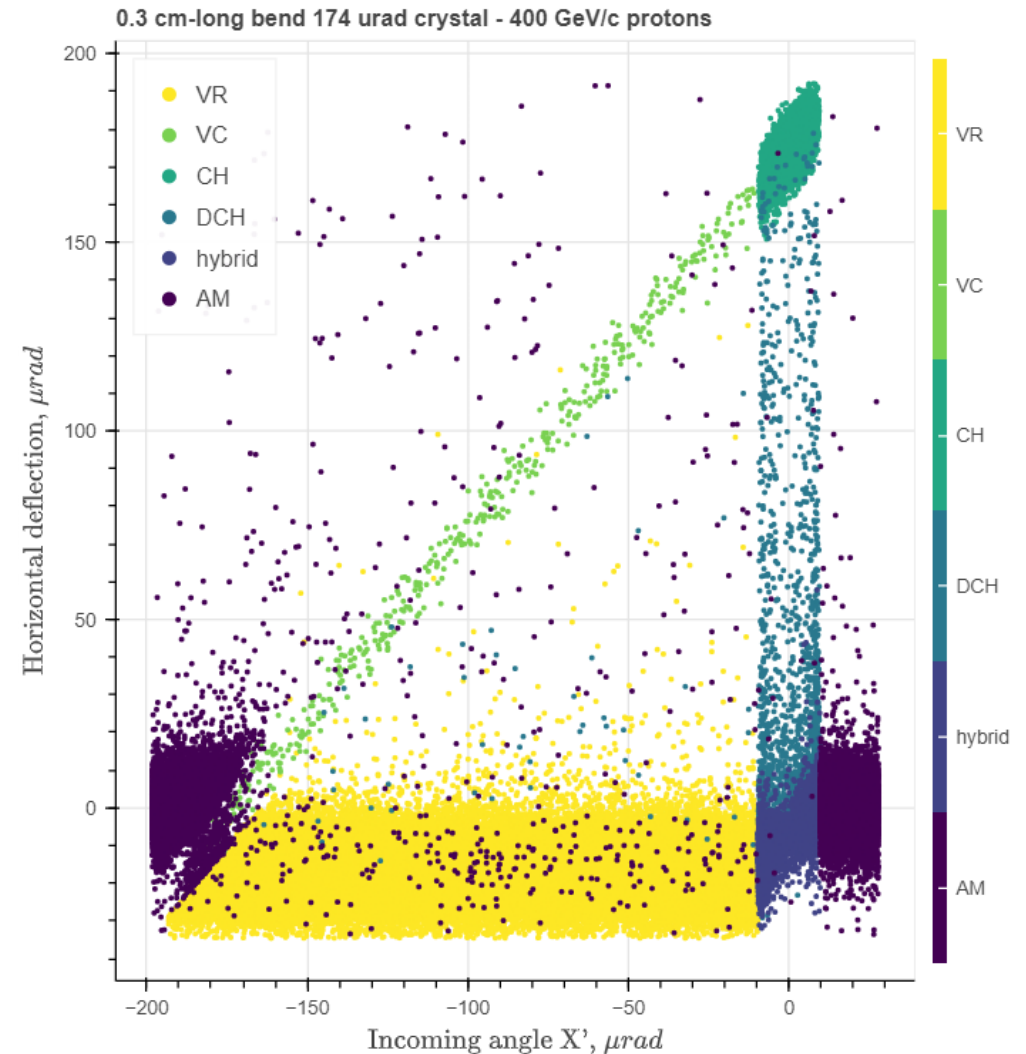

Introduction: Beam Loss Monitoring (BLM) system

CDS, Photo by M. Brice

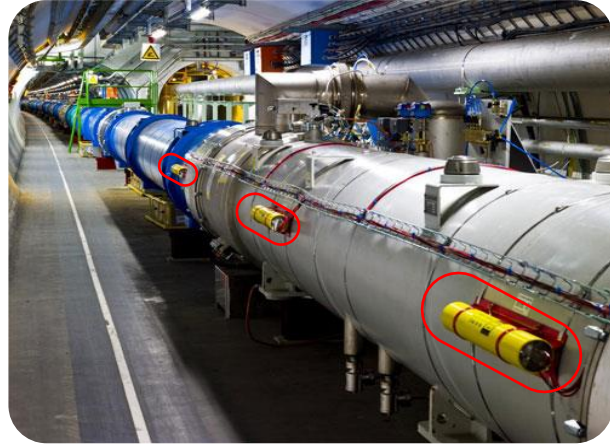

[1]

In picture



In simulation

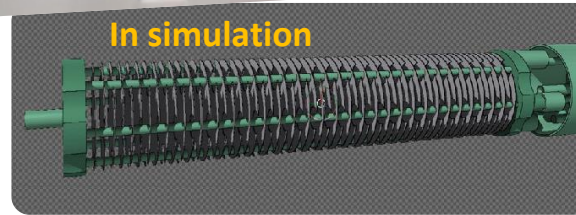

- BLM ionization chambers (ICs) are filled with pressured nitrogen (1.1 atm)

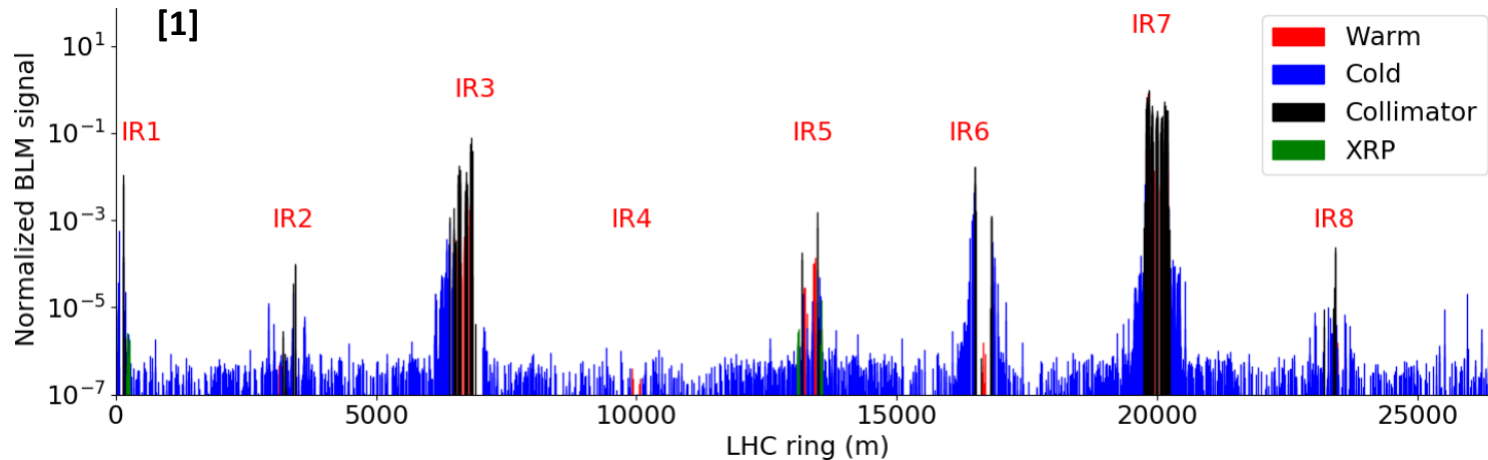

- Full ring can be characterized via a “loss map” that show how losses are localized

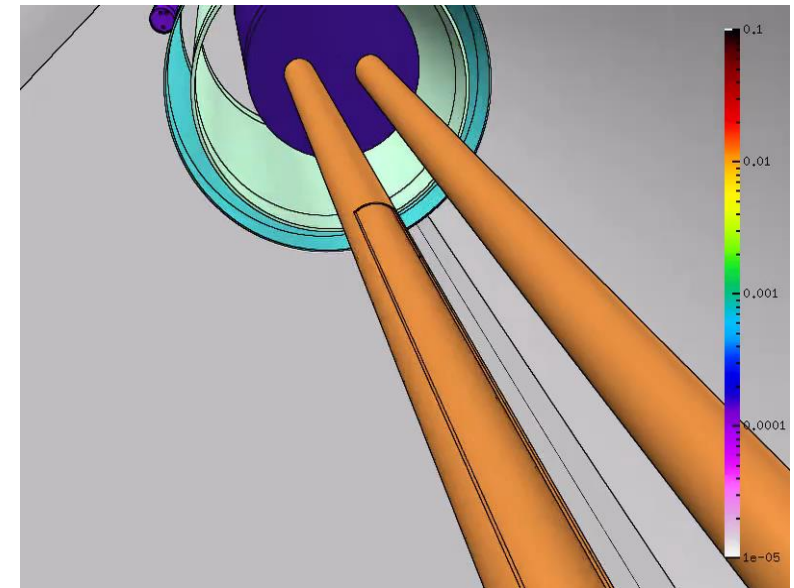

[1] Beam diagnostics for studying beam losses in the LHC (B.Salvachua)

Global simulation workflow : Schematic view

Required input:

- Generic parameters
- Optics input from MAD-X
- Losses from SixTrack
- Drawings and materials from EDMS and CDD
- Location of elements from CERN layout database
- Simulation in Fluka (Geometry + Loss distribution)

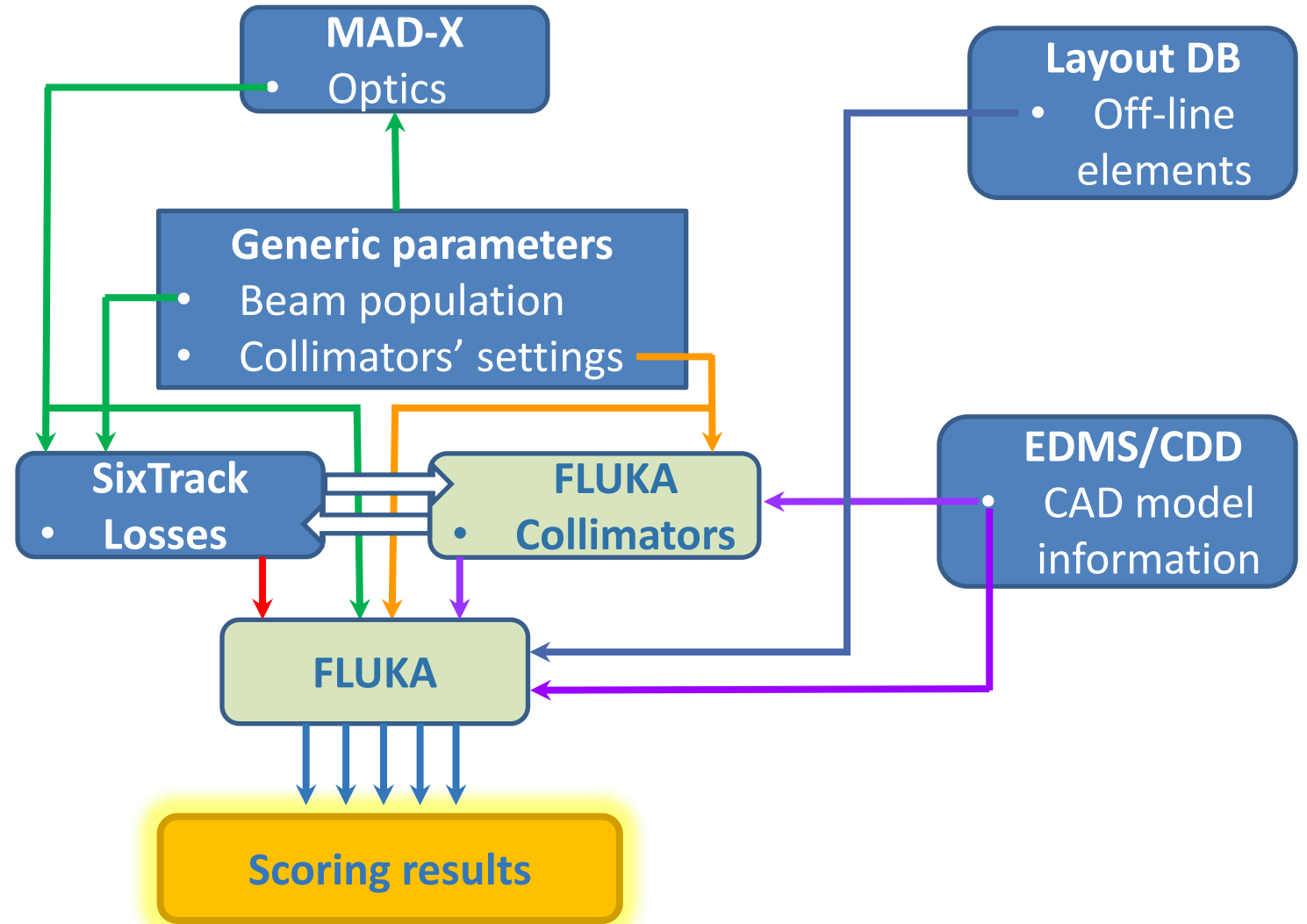

Case study: Power deposition with 6.8 ZTeV ions in Run 3

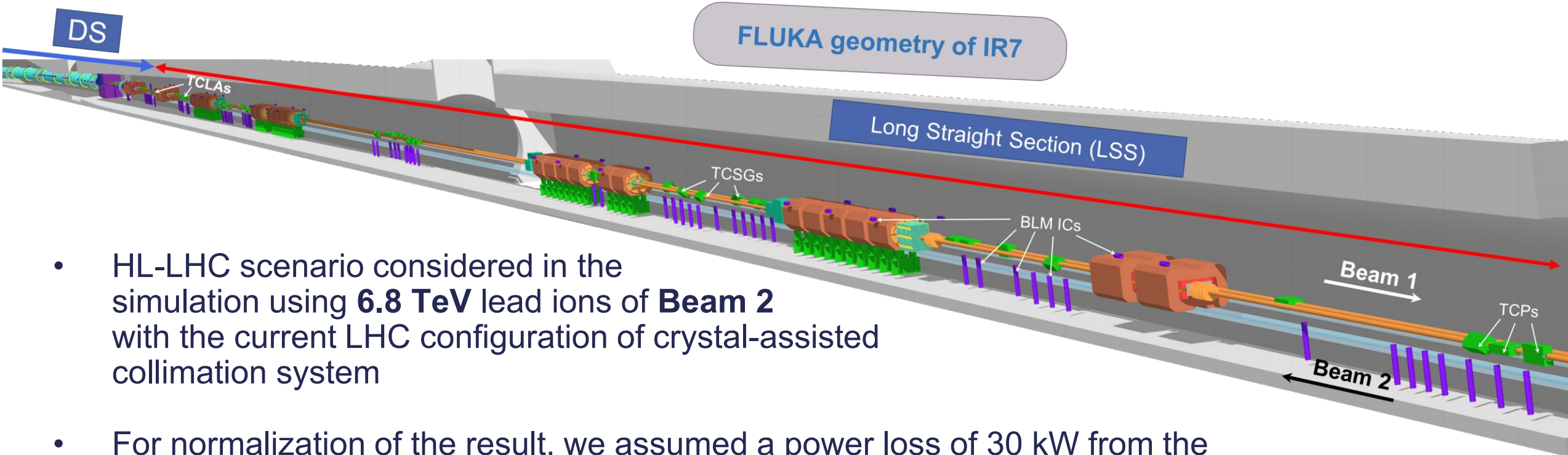

- HL-LHC scenario considered in the simulation using **6.8 TeV** lead ions of **Beam 2** with the current LHC configuration of crystal-assisted collimation system
- For normalization of the result, we assumed a power loss of 30 kW from the beam, corresponding to the loss rate of 3.1×10^8 lead ions/s, defined from BLM loss map thresholds
- 3D scoring in polar coordinates system was defined for each superconducting dipole or quadrupole with resolution $3 \text{ mm} \times 2 \text{ deg} \times 10 \text{ cm}$

Crystal-based collimation system: Cleaning performance

- Reference study for comparison [1], with previous version of HL-LHC configuration (**HL22**) and different crystals at **7 ZTeV**
- Crystal collimation decreases peak power deposition in DS superconducting coils by factor >3 for most of the magnets

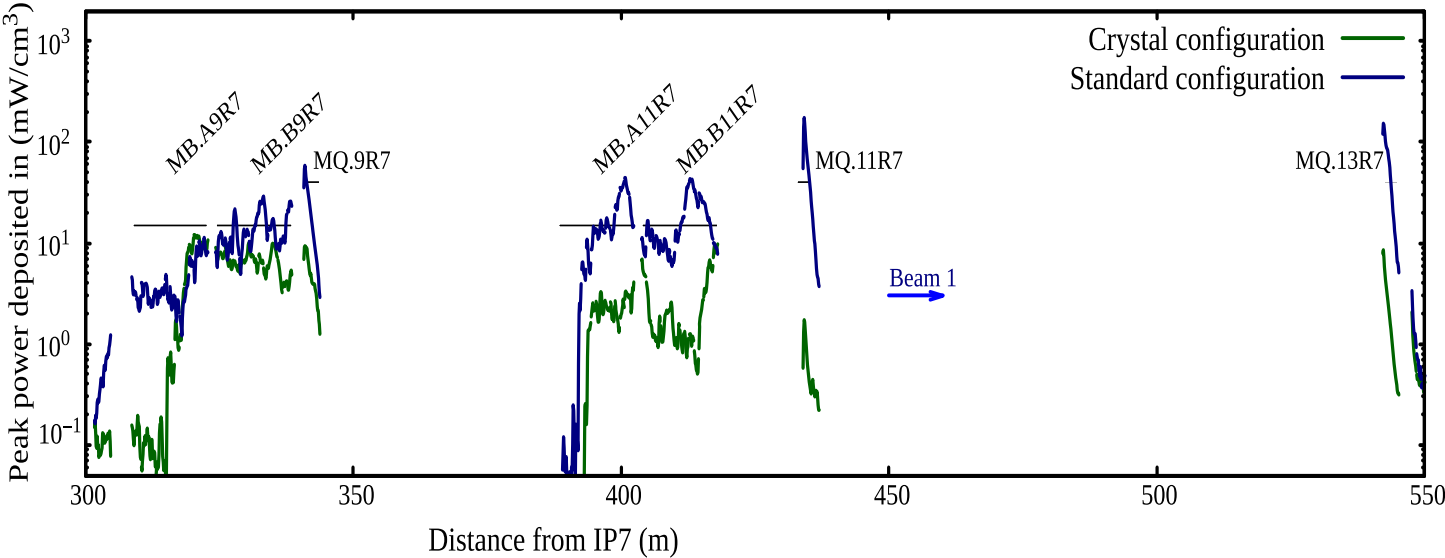

- Leakage of ion fragments into DS was decreased

J. B. Potoine *et al* Phys. Rev. Accel. Beams **26**, 093001

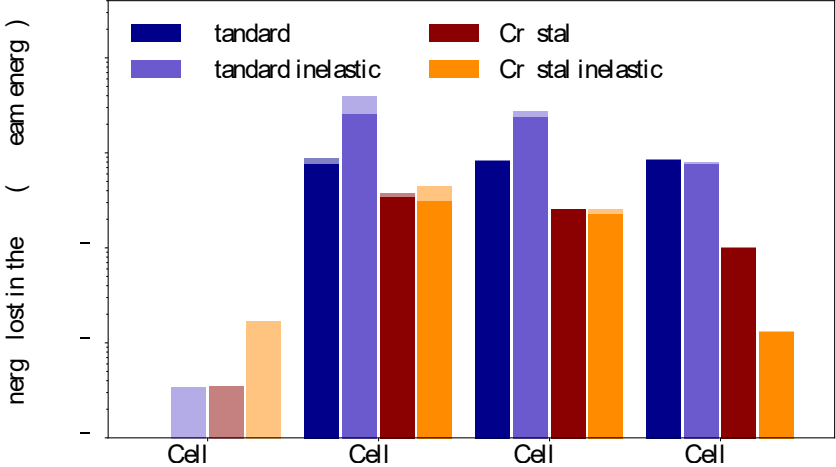
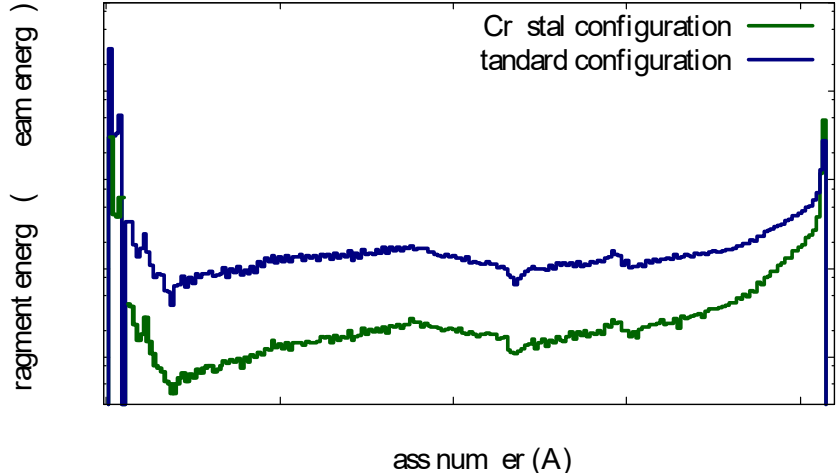

Crystal-based collimation system: BLM benchmark

- Crystal study of the **27/11/18 MD at 14h24 – B1**, artificial beam generation in **horizontal plane**, **Run 2** collimation system settings with ion beam at **6.37 ZTeV**
- Quite good agreement in the DS

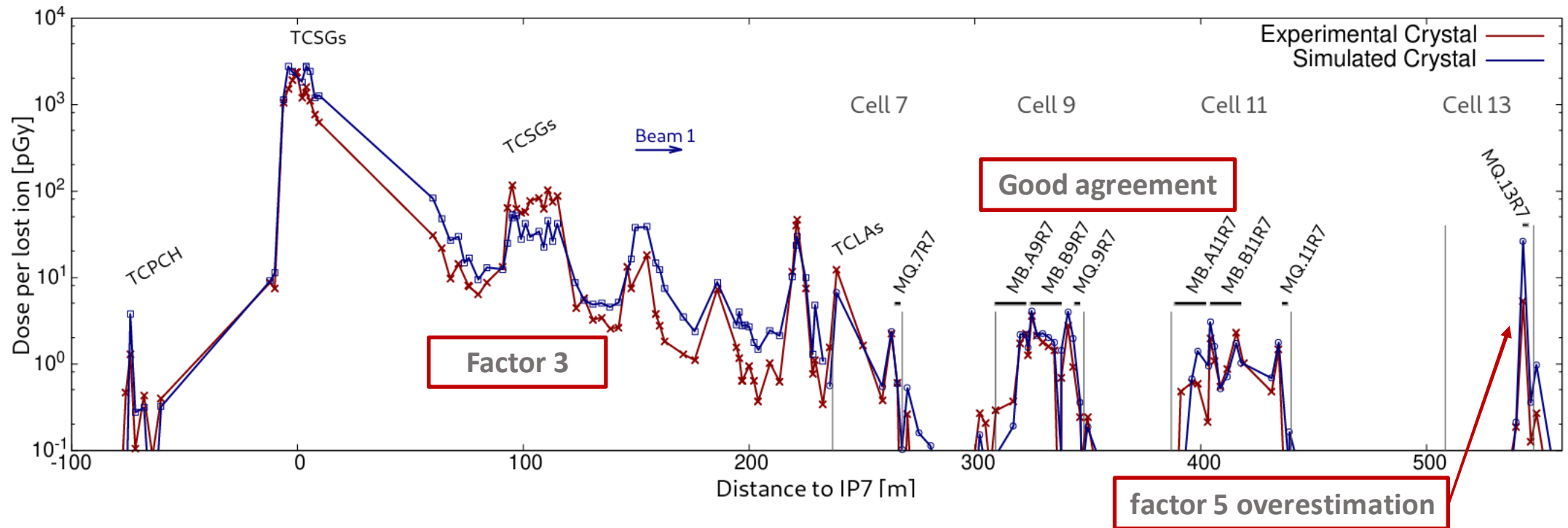

J. B. Potoine *et al* Phys. Rev. Accel. Beams **26**, 093001

Power loss density in both beams, side to side: old and new settings

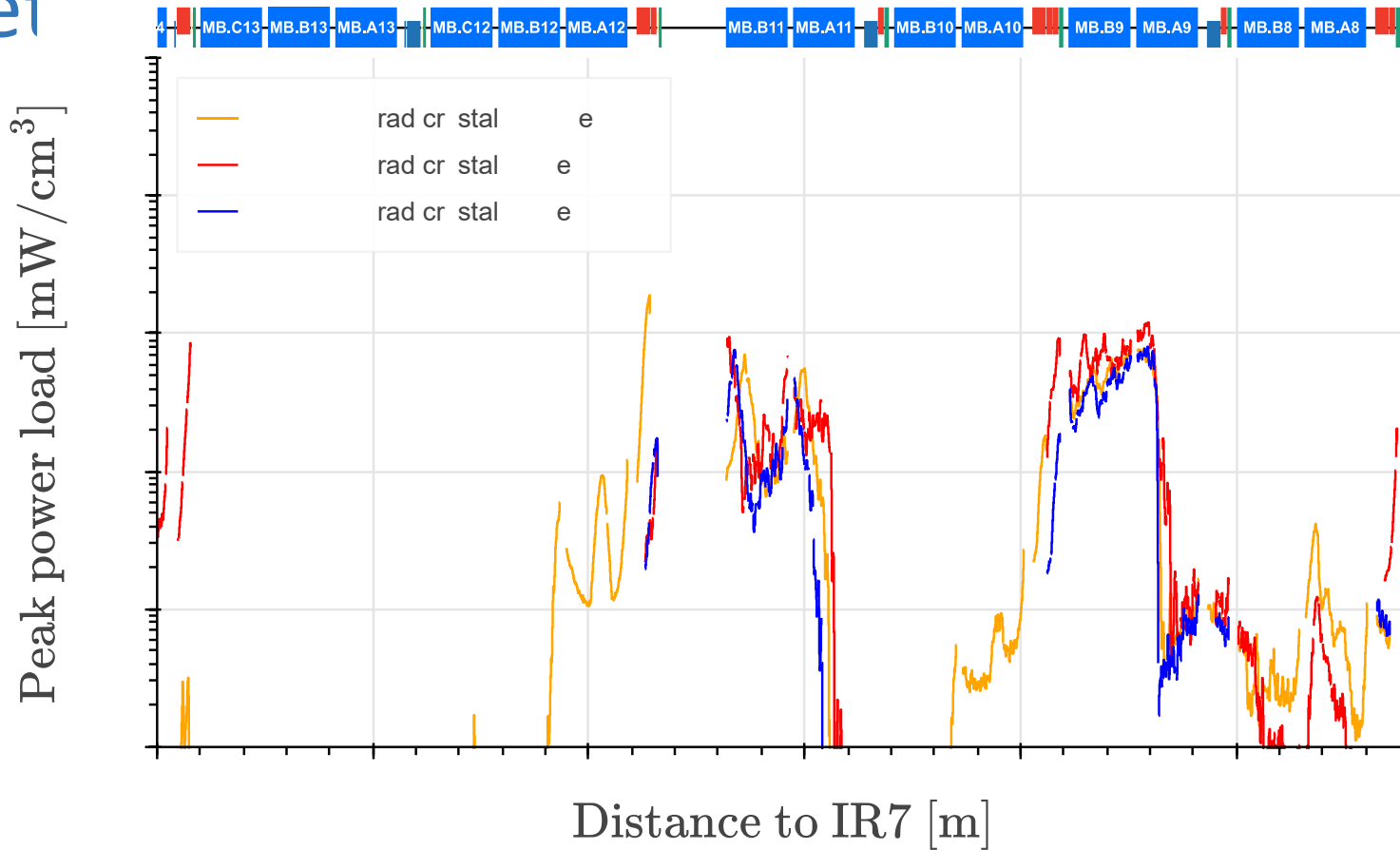

- Radially averaged value in the inner coil

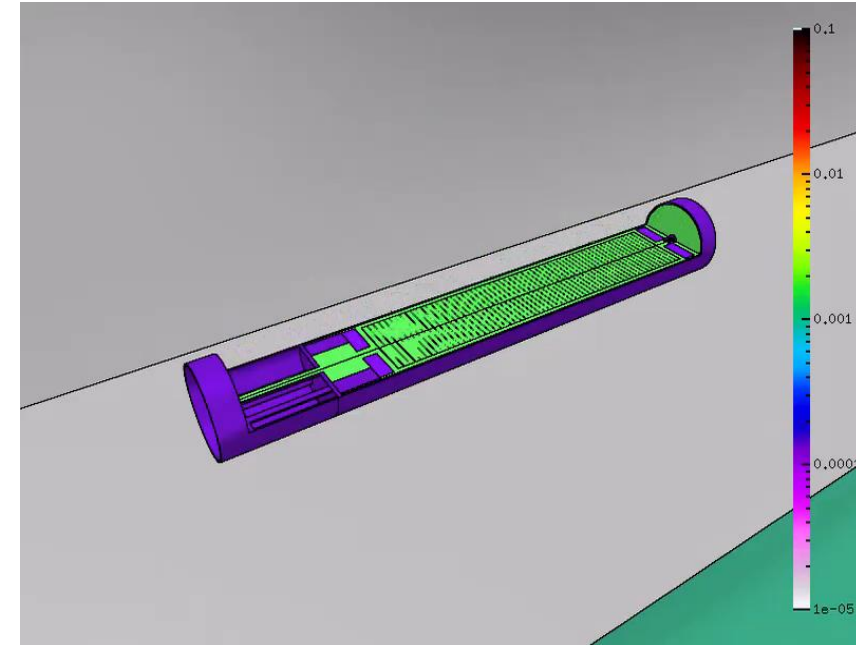

- Normalization applied for direct comparison:

- Good match in loss pattern between **HL22 B1** and **HL23 B2**, when crystal bending is quite close

Fragment loss map analysis: HL22 B1 vs HL23 B2

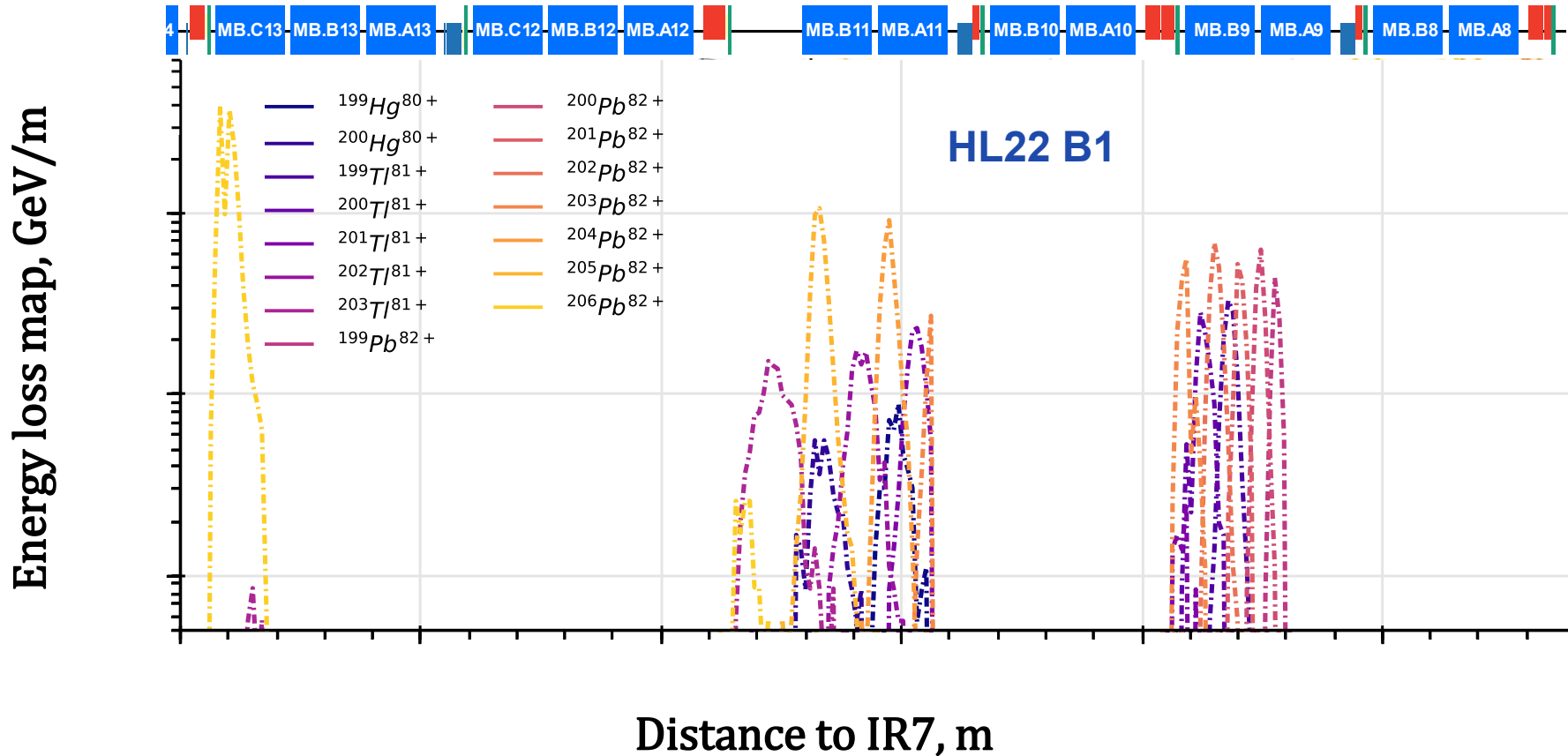

- Normalization factors applied for direct comparison

- Value is shown per primary particle

- **Major shifts** for:



- The displacement of some ion fragments further downstream is happening due to higher magnetic rigidity and also because of a slight asymmetry in optics between Beam 1 and Beam 2

Power deposition — Quench levels

[1]

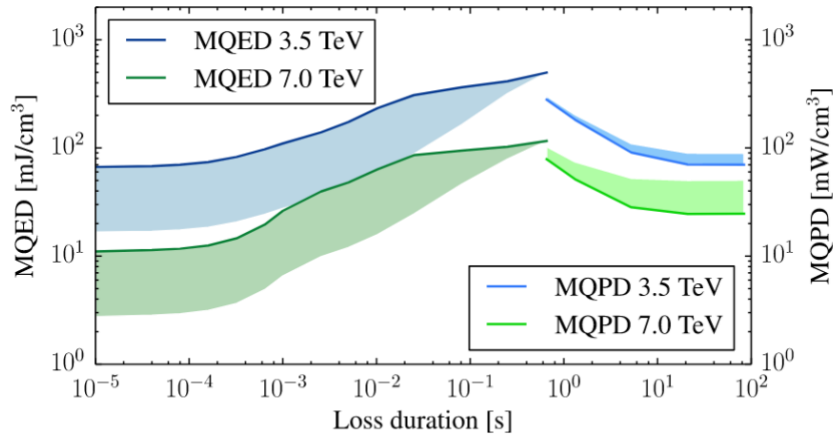

Electro-thermal simulations for 7 TeV [1]:

- Q quench level mW/cm^3 (pessimistic cooling model)
- quench level mW/cm^3 (pessimistic cooling model)
- an e order of value is assumed for protons

FIG. 24. Electrothermal quench level estimates for the inner layer of the LHC main bending magnet. Shading in the MQED

[2]

• Still some uncertainties remain regarding actual quench level at 6.8 and 7 ZTeV

	()	(e)	es	Const for	s	m	cm	10	m	cm
Collim	()	(e)	es	ising for	s	m	cm		m	cm
Collim	()	p (e)	o	ising for	s	20-25 mW/cm ³ (x)				
Collim	()	p (e)	o	ising for	s	m	cm		m	cm

[1] Testing beam-induced quench levels of LHC superconducting magnets (B.Auchmann)

[2] BLM threshold strategy for the 2023 Pb run (A. Lechner, 96th BLM Thresholds Meeting (Pb run))

Summary & Outlook

- Power deposition distributions in the superconducting magnets were obtained using FLUKA for the HL-LHC baseline configuration for Run3
- Satisfactory reduction of the power density in IR7 - DS magnets with crystal collimation even though there is some uncertainties about the actual quench levels.
- Power deposition in DS dipoles (~ 12 mW/cm³) from Beam 2 losses should remain below the expected quench limits in case of a lifetime drop . Much larger margin for quadrupoles.
- Losses in the DS are coming almost exclusively from inelastic/EMD interactions in the crystal/ primary collimators.
- A separate assessment for Beam 1 (crystal with different channeling efficiency) is ongoing.

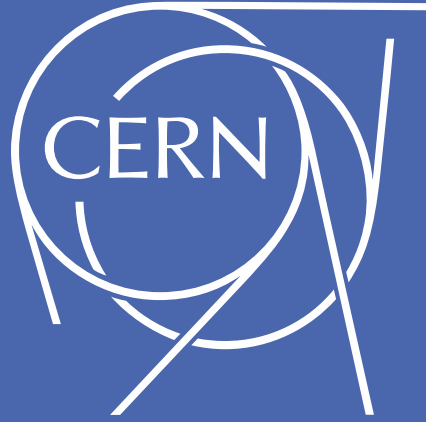

**Thanks for your
attention!**

**Any questions are
welcome!**