

Beam Diagnosis and Soundness Check System for Neutrino Production Targets

Megan Friend

High Energy Accelerator Research Organization (KEK)

HB2023, October 11, 2023

Outline

- Conventional High-Energy, High-Power Neutrino Beamlines
- Target Conditions Monitoring
- Primary Beam Profile Monitoring
- Tertiary Beam Profile Monitoring
- Neutrino Beam Monitoring
- Machine Learning Applications for Monitoring

Neutrino Beam Production

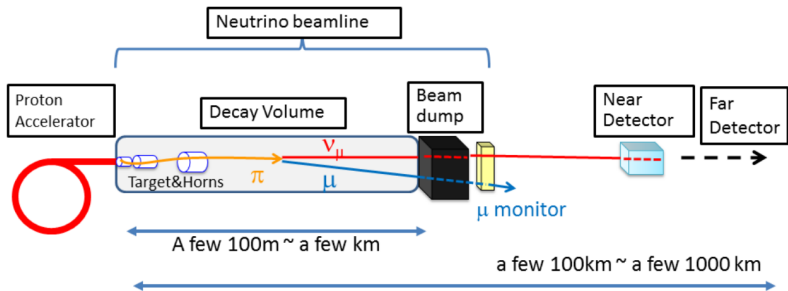

- Slam high-energy, high-intensity proton beam into long target
- Focus outgoing hadrons in electro-magnetic focusing horns
- Pions decay to muons and muon-neutrinos in long decay volume
- Stop interacting particles in beam dump and earth; neutrinos continue on to near and far detectors for neutrino experiments
 - Instrument beam dump to continuously monitor muon beam
- Number of neutrinos is proportional to number of protons incident on the target – maximize proton beam power to maximize flux

J-PARC Neutrino Beamline Components

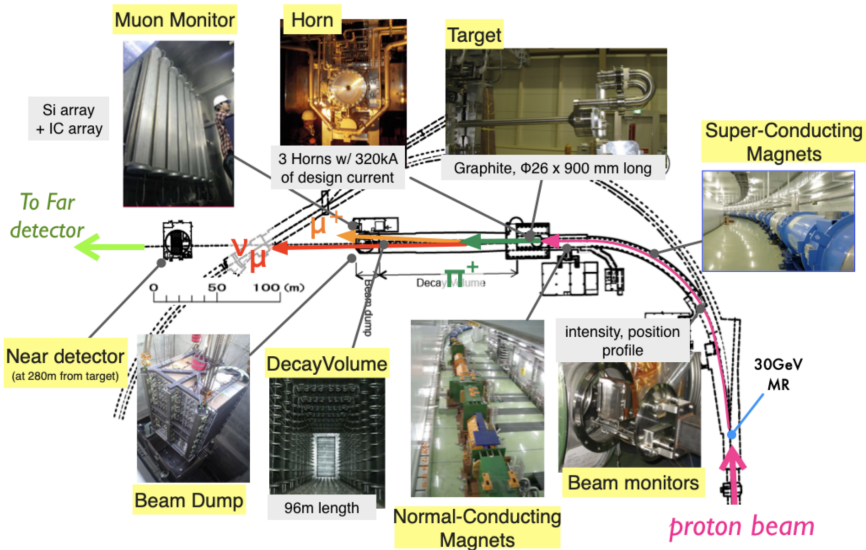

Proton Beams for Neutrino Experiments

J-PARC neutrino beamline for the T2K + future Hyper-K experiments, etc.

- Beam Energy: 30 GeV
- Beam Power: 500 kW
→ 1.3 MW
- Beam Intensity: $2.4E14$ ppp
→ $3.2E14$ ppp
- Beam Bunches: 8
- Pulse Length: $4.2 \mu\text{s}$
- Duty cycle: $2.48 \text{ s} \rightarrow 1.16 \text{ s}$
- Beam spot size at target: 4 mm
- Running since: 2009

NUMI neutrino beamline @FNAL for the NO ν A experiment, etc.

- Beam Energy: 120 GeV
- Beam Power: 780 kW
→ 1 MW
- Beam Intensity: $5.4E13$ ppp
→ $6.5E13$ ppp
- Beam Bunches: 588
- Pulse Length: $11 \mu\text{s}$
- Duty cycle: $1.333 \text{ s} \rightarrow 1.2 \text{ s}$
- Beam spot size at target: 1.3 mm → 1.5 mm
- Running since: 2005

See Monday talks by Y. Sato and J. Eldred

Proton Beams for Neutrino Experiments

J-PARC neutrino beamline for the T2K + future Hyper-K experiments, etc.

- Beam Energy: 30 GeV
- Beam Power: 500 kW
→ 1.3 MW
- Beam Intensity: $2.4E14$ ppp
→ $3.2E14$ ppp
- Beam Bunches: 8
- Pulse Length: $4.2 \mu\text{s}$
- Duty cycle: $2.48 \text{ s} \rightarrow 1.16 \text{ s}$
- Beam spot size at target:
4 mm
- Running since: 2009

LBNF neutrino beamline @FNAL for the future DUNE experiment

- Beam Energy: 60-120 GeV
- Beam Power: 1.2 MW
→ 2.4 MW

Under Design

See Monday talks by Y. Sato and J. Eldred

Neutrino Production Target

- At J-PARC
 - Monolithic graphite target, 91.4-cm-long, 26mm diameter, cantilevered mounting
 - Two co-axial pipes for He gas cooling and Ti-alloy target container
 - Upstream structure for single-side He gas port
- Similar (longer) target to be used for LBNF

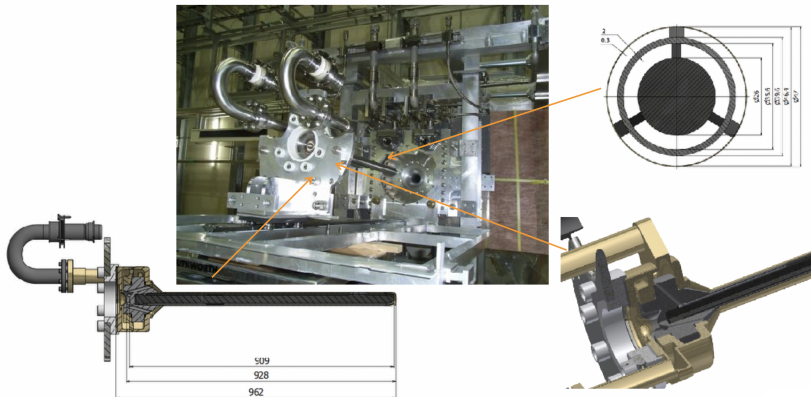

Why Are Extracted Beam Diagnostics Important?

- Continuously impinging an offset or too narrow high-intensity beam on the production target or beam window could cause serious damage
- Even one shot of mis-steered high-intensity beam can seriously damage equipment
 - Need continuous monitoring
 - At J-PARC NU beamline, a beam abort interlock signal is fired if :
 - Beam position becomes significantly offset from centered
 - Beam density at target becomes $N_p/(\sigma_x \times \sigma_y) < 2 \times 10^{13}$ ppp/mm²
- Information from proton beam monitors is used as input into the neutrino flux prediction simulation
 - For neutrino oscillation experiments + neutrino cross section measurements
 - Need well-understood and well-controlled proton beam for world-class neutrino physics results

Target Monitoring

- At J-PARC:
 - Continuously monitor the temperature of the target frame
 - Continuously monitor the temperature of the He gas used for cooling the target at both the inlet and outlet
 - Periodically sample target cooling He gas
 - Impurity measurement by gas-chromatography: O₂, CO, CO₂, H₂, CH₄, N₂
 - Tritium measurement
 - Further upgrades planned (H₂O contamination measurement, etc)

FEM

T2K target - 400kW beam spot (Flux 2018) - 300kW 4 24mm sigma
 Mass flow rate = 0.2222 [kg/s] Power rate = 1228.0 [W]
 Outlet pressure = 0.1666 [bar] Pressure drop = 0.00077 [bar]
 Inlet temperature = 300 [K] Outlet temperature = 389 [K]
 Graphite max temperature = 622.828 [K] Target area max temperature = 622.828 [K]
 US window max temperature = 516.881 [K]
 US window max temperature = 388.008 [K]

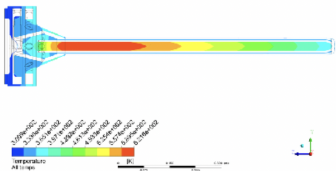

480kW 22.8[g/s] No. Rad. damage
 He: 300K → 389K
 Graphite: 622K max.

Real Measurement

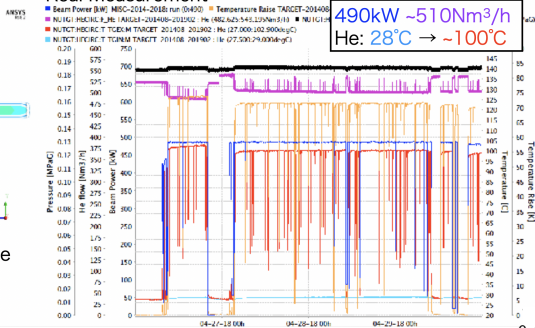

J-PARC Neutrino Beamline Monitors

Primary Beamline Monitors

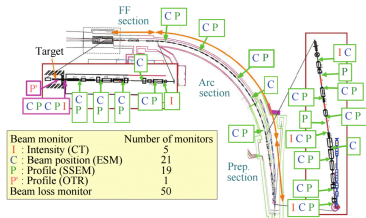

Final Focusing Section

Beam Direction →

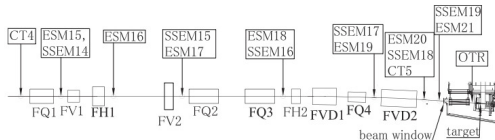

- 5 CTs (Current Transformers) – monitor proton beam current
 - 50 BLMs (Beam Loss Monitors) – monitor proton beam loss
 - 21 ESMs (Electrostatic Monitors) – monitor proton beam position
- ↑ These are non-interacting and should work stably even at 1.3MW ↑
- ↓ These are interacting and may degrade at high beam power ↓
- 18 SSEMs (Segmented Secondary Emission Monitors) + 2 WSEMs (Wire SEMs) – monitor beam profile during beam tuning
 - 1 OTR (Optical Transition Radiation) Monitor – monitors proton beam position and profile at target
 - 1 MUMON (Muon Monitor) – continuously monitor muon beam

J-PARC NU Segmented Secondary Emission Monitor (SSEM)

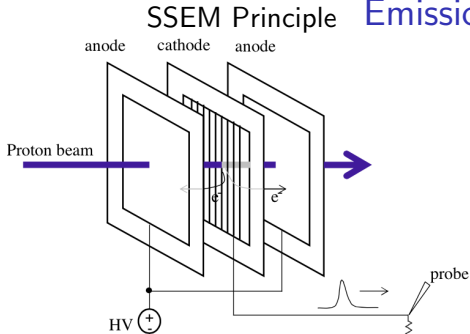

- Protons interact with foils
- Secondary electrons are emitted from segmented cathode plane
- Compensating charge in each strip is read out as positive polarity signal
- Used for periodic beam tuning

J-PARC NU SSEM

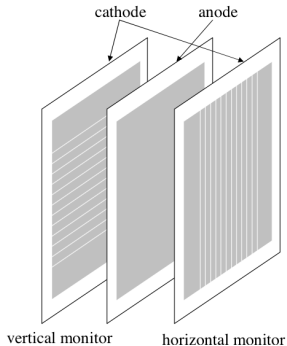

- Single anode plane between two stripped cathode planes
- 5 μm thick Ti foils

J-PARC NU Beam Loss Due to SSEMs

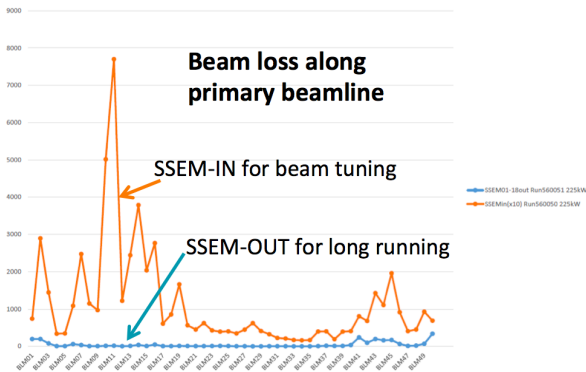

- Each SSEM causes $\sim 0.005\%$ beam loss
- Can cause radiation damage, activation of beamline equipment
 - SSEMs upstream of the neutrino target station cannot be used continuously – only used during beam tuning and optics checks

J-PARC NU SSEM Foil Discoloration

- Most downstream SSEM has been used continuously since 2009
- Foil inspection was performed in summer 2017 (downstream side) and fall 2018 (upstream side)
 - Significant discoloration of foils observed
 - No significant signal degradation, but plan to replace the monitor head

Downstream side after
 $\sim 2.3 \times 10^{21}$ Incident Protons

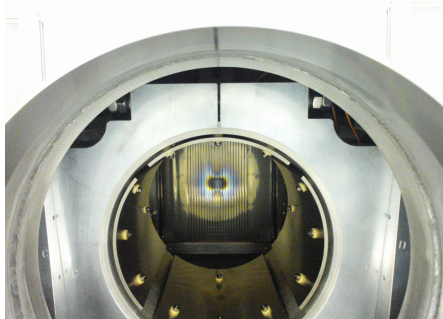

Upstream side after
 $\sim 3.2 \times 10^{21}$ Incident Protons



Reduce Material to Reduce Beam Loss

- Developed wire profile monitors for J-PARC in collaboration with engineers at FNAL as a US/Japan collaborative project
 - Same design used at FNAL, but larger aperture needed at J-PARC
- Developed monitor with twinned 25 μm Grade 1 Ti wires
 - Same principle as SSEMs but with reduced material in the beam
 - 10x reduced beam loss → can use continuously further upstream
 - Maintain signal size at low beam power by maximizing surface area
 - Beam test for 160 hours in 460~475kW J-PARC beam → no issue
 - Can further upgrade wire material to be more robust
 - Plan to test Carbon Nano-Tube (CNT) wire at J-PARC soon

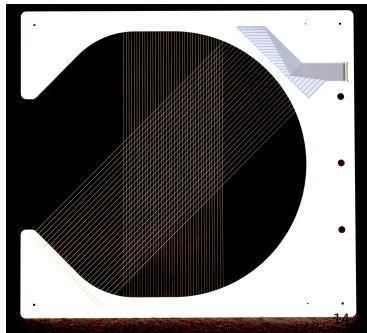
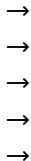

J-PARC NU Optical Transition Radiation Monitor (OTR)

- Continuously monitors beam profile directly upstream of the target
- OTR light is produced when charged particles travel between two materials with different dielectric constants
- Monitors backwards-going light from 50- μm -thick Ti foil
 - Light is directed to TS ground floor by a series of 4 mirrors and then monitored by a rad-hard CID camera
- Rotatable disk w/ 8 foil positions; until 2022 :
 - 4x Ti alloy (for physics running)
 - 1x ceramic (for low-intensity tuning)
 - 1x cross-pattern holes
 - 1x calibration holes
 - 1x empty

S. Bhadra *et al.*,
Nucl. Instr. and Meth. A
 vol. 703, 45-58, 2013

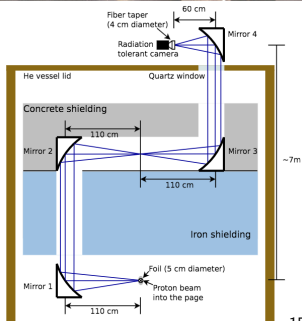
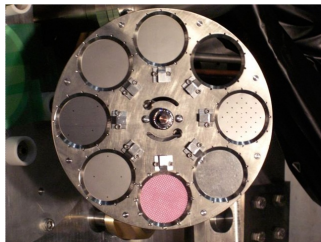

J-PARC NU OTR Stability

Foil Discoloration :

- OTR foil discoloration seen after incident :
 - $\sim 5 \times 10^{20}$ POT on Ti Foil
 - $\sim 11 \times 10^{20}$ POT on Cross Foil
- Gradual decrease of OTR light yield
 - Originally believed due to foil degradation...
 - Actually due to radiation-induced darkening of leaded-glass fiber taper on CID camera

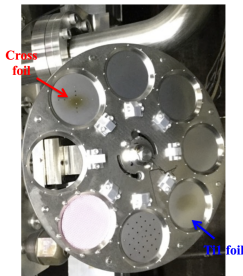

OTR Normalized Light Yield (Stability) :

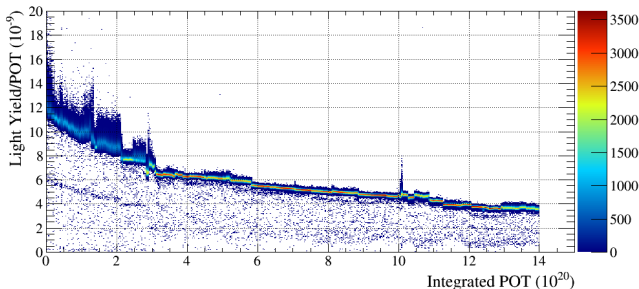

J-PARC NU Beamline OTR Upgrades

- Decrease in OTR yield observed, also had issues with disk rotation system (microswitch/disk alignment)
- Various upgrades carried out in 2022:
- Upgraded optical system to use easily-replaceable (inexpensive) fiber taper – regularly replace as it becomes dark
- Useful to have backup procedure for OTR calibration + foil position information
- Added holes to all OTR target foils
 - Can be used to cross check foil position by back-lighting
 - Reduced foil thickness $50\mu\text{m} \rightarrow 33\mu\text{m}$ for improved stress tolerance with holes
- Upgraded readout system Windows \rightarrow Linux

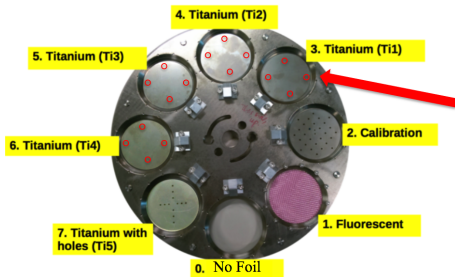

NUMI “Hylen Device” Principle and Design

Beryllium rods, near upstream window of target, to watch beam position

(not to scale; also baffle drawn behind target, although it is actually in front)

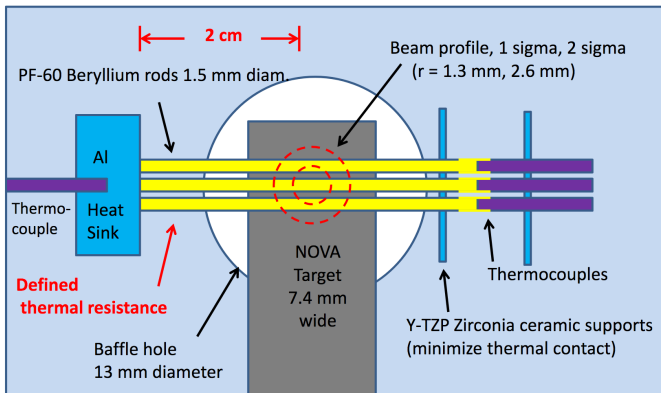

J. Hylen, “Thermal Position Monitor”,
NBI2014

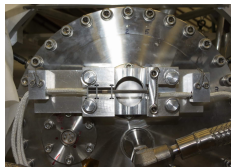

- ΔT (Rod - Sink) \propto (beam power deposition in rod)
→ Coarse profile derived from ratio of ΔT 's of the different rods
- Thermocouples same material as the beam window – very robust
- ΔT is bulk phenomenon – surface degradation doesn't matter

NUMI “Huyen Device” Disadvantages

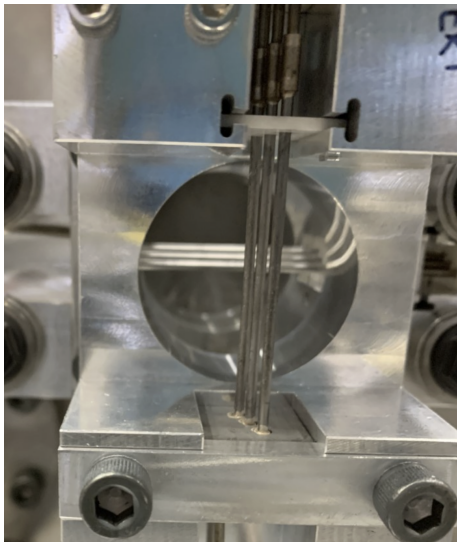

- Only 3 thermocouples means profile reconstruction is quite coarse
 - Upgrade to increase number of thermocouples(?)
- Doesn't work pulse-by-pulse – requires stable beam operation
 - Characteristic timescale is ~9 s; wait ~1 minute for good stability
- Needs order 1°C temperature difference to provide reasonable measurement
 - Limited range
 - Doesn't work for low-intensity tuning

J-PARC Beam Induced Fluorescence (BIF)

- BIF monitor uses fluorescence induced by proton beam interactions with gas injected into the beamline
 - Protons hit gas (i.e. N_2) inside the beam pipe
 - Gas molecules are excited or ionized by interaction with protons
 - Fluoresce during de-excitation with same profile as proton beam
- Continuously and non-destructively monitor proton beam profile
 - $5 \times 10^{-8}\%$ beam loss for 1m of gas at 10^{-2} Pa
 - $\sim 10^{-5}$ x less beam loss than 1 SSEM
- Locally degrade vacuum level from $\sim 10^{-5}$ \rightarrow $\sim 10^{-2}$ Pa to observe ~ 1000 BIF photons/spill at photo-detector – Challenging!
 - Essential to optimize gas injection + light transport/detection
- 2x optical systems (for horizontal + vertical readout):
 - 1x conventional integrating image intensifier + camera
 - 1x fast readout using optical fibers + MPPCs

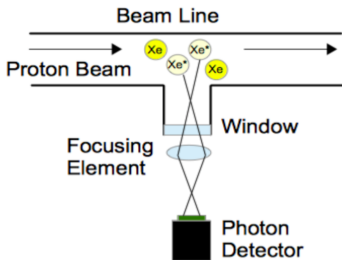

J-PARC Prototype BIF Results

Beam image at camera (1 spill):

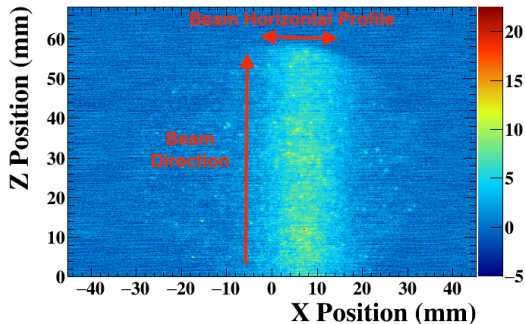

- $\sim 4e6$ V/m beam-induced space-charge field at J-PARC
- Concern that ionized particles would drift in beam space-charge field
→ Measure time dependence of BIF profile using fast readout

- Clear beam signal across camera sensor
- Gaussian fit to extract beam position + profile

Profile with optical fibers:

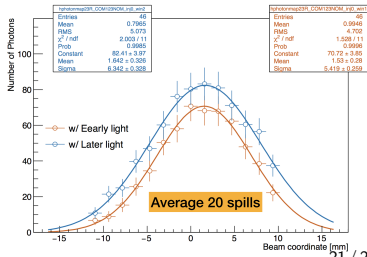

Muon Monitoring

- Measure tertiary muon beam profile downstream of the decay volume, beam dump
- At J-PARC: 2 redundant measurements of the muon beam profile, position using 2 7x7 arrays of sensors ($> \sim 5$ GeV muons)
 - Ionization chambers (IC)
 - Silicon photodiode sensors (Si)
- At NuMI: 3 9x9 arrays of IC at different distances in rock

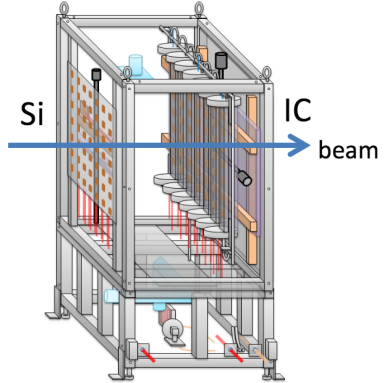

Some issues :

The signal ratio of Si to IC (IC signal is stable within 0.2%)

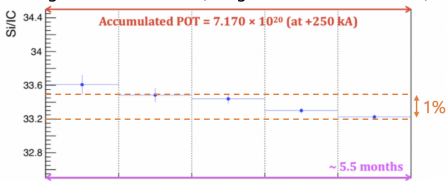

IC signal / proton beam intensity vs. proton beam intensity

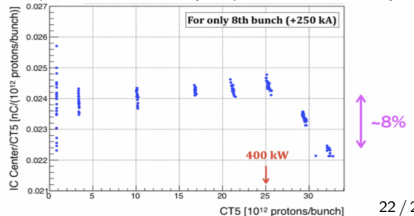

MUMON EMT

- Now developing Electron Multiplier Tube (PMT w/out photocathode) as more robust muon sensor option
 - Several dedicated beam tests carried out (@ELPH + J-PARC muon pit)
→ Very promising results

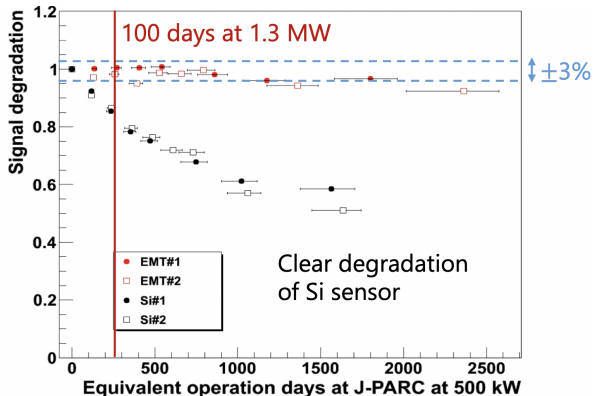

NuFACT2022
(T. Honjo)

Neutrino Beam Monitoring

- Also important to continuously monitor neutrino beam stability
 - Neutrino beam interaction cross section is very low, so takes order days~weeks to get sufficient statistical errors
 - J-PARC on-axis neutrino beam measurement:

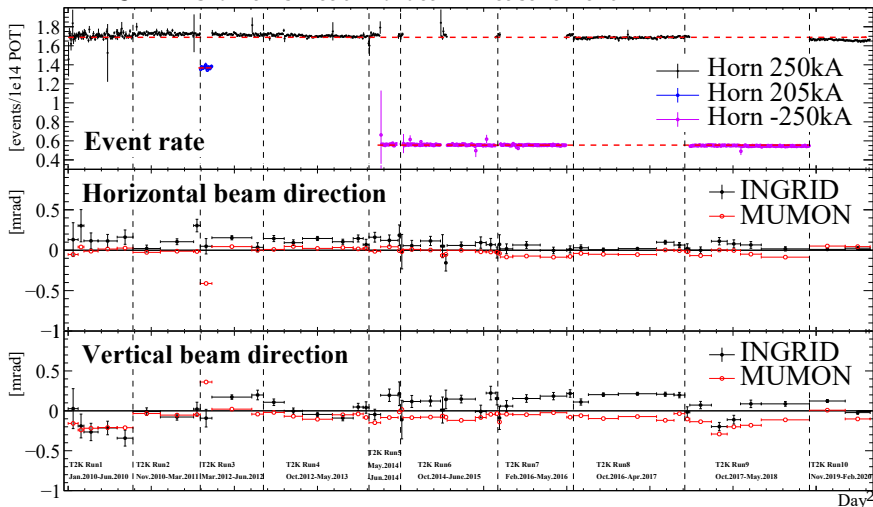

Neutrino Beam Monitoring

- Can be used to diagnose major issue with production target
- NuMI Target degradation observed at neutrino near detector:

Gradual decrease in neutrino rate attributed to target radiation damage

Decrease as expected when decay pipe changed from vacuum to helium fill

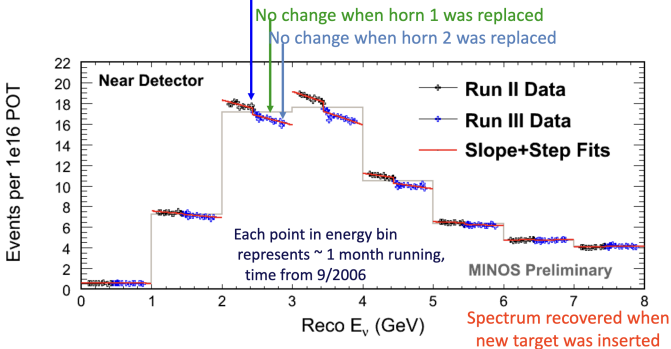

Degraded NT02 target:

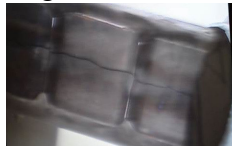

Putting It All Together

- Need information from all of these various sources to understand the beam/target condition
 - Temperature sensor information, proton beam information, muon beam information, neutrino beam information, ...
- J-PARC strategy: continuously monitor, stop operation + tune the beam if there are deviations
- At NuMI, recently developed Machine Learning technique
 - Training using data from various instruments
 - Use muon monitor information to predict those parameters
→ Understand and maintain the neutrino beam quality
 - Incredible agreement between data and prediction

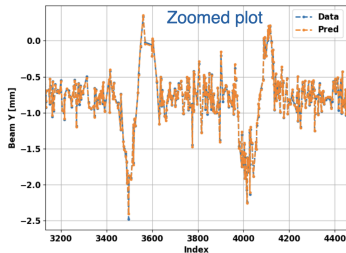
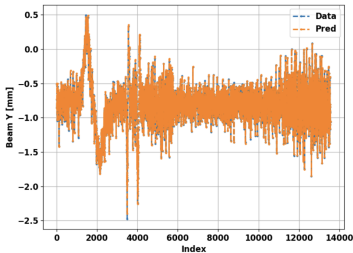

NuFACT2022 (A. Wickremasinghe)

Conclusion

- Continuous monitoring is essential for successfully running fixed target neutrino extraction beamlines
 - Direct target monitoring
 - Proton beam position and profile monitoring
 - Muon beam monitoring
 - Neutrino beam monitoring