

PAUL SCHERRER INSTITUT



P. A. Duperrex, J. Sun, J.E. Bachmann, M. Rohrer :: GFA :: Paul Scherrer Institute

Improvement Design of a Beam Current Monitor based on a Passive Cavity Under Heavy Heat Load and Radiation

11.10.2023



- **Introduction**
- **Performance of the Graphite Monitor**
- **On-line calibration**
- **Improvement design**

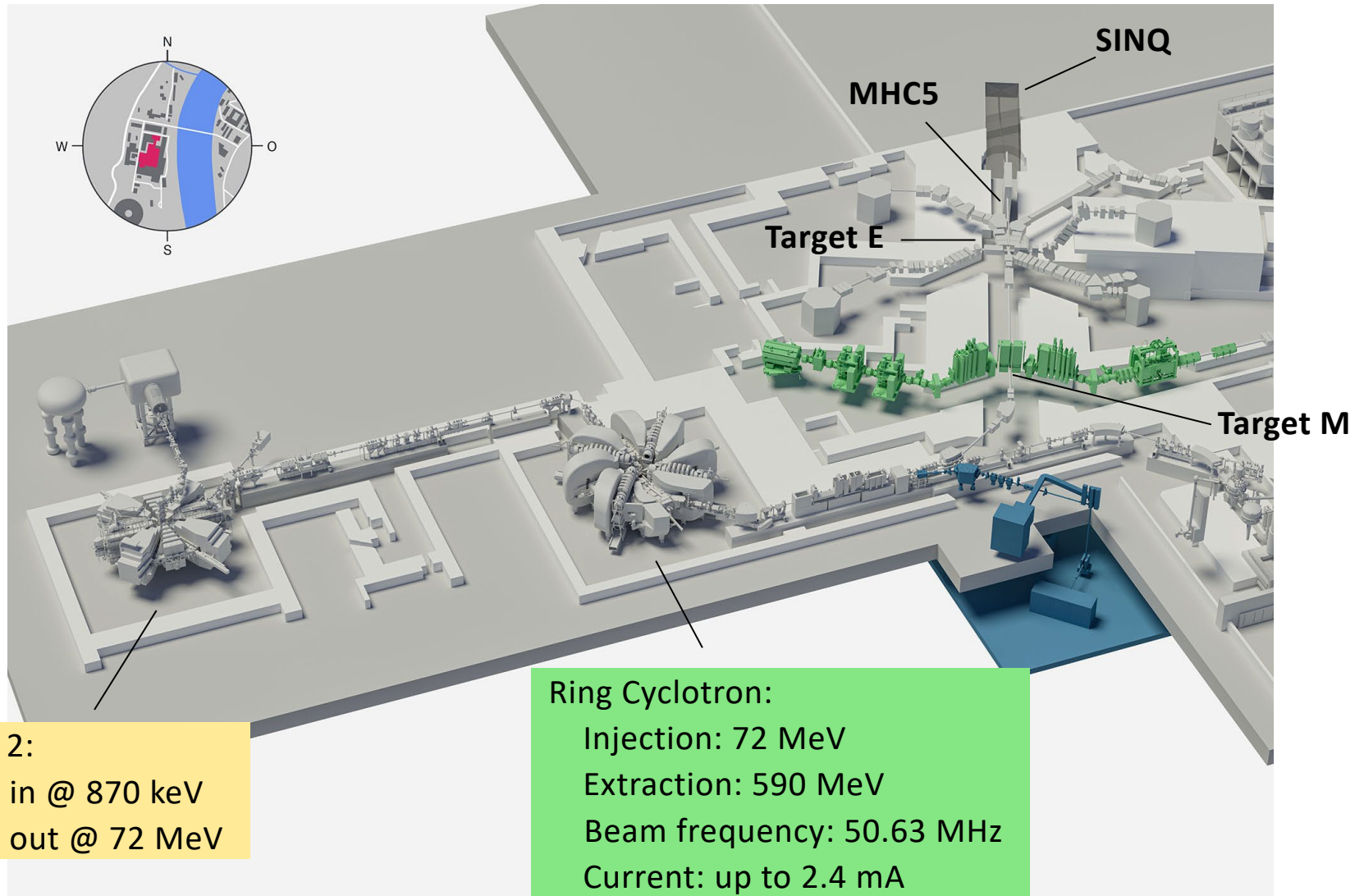

Injector 2:
 Beam in @ 870 keV
 Beam out @ 72 MeV

Ring Cyclotron:
 Injection: 72 MeV
 Extraction: 590 MeV
 Beam frequency: 50.63 MHz
 Current: up to 2.4 mA

Resonant frequency:

$$\omega_0 = \frac{1}{\sqrt{L.C}}$$

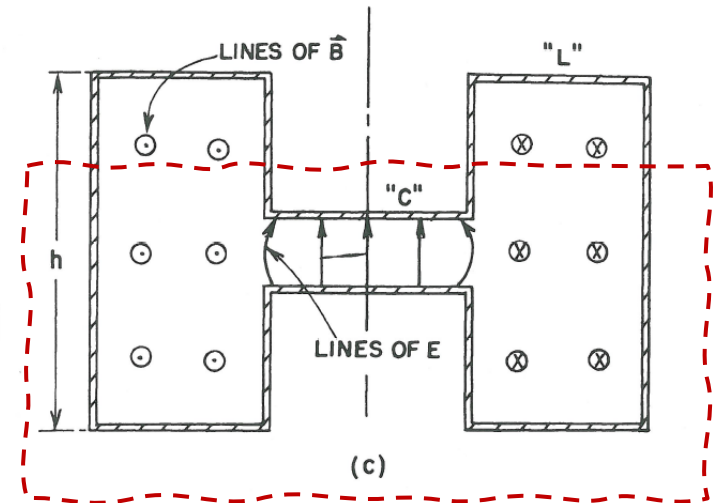
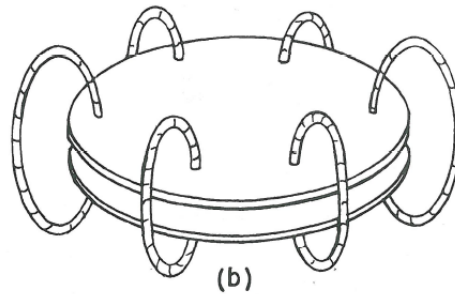
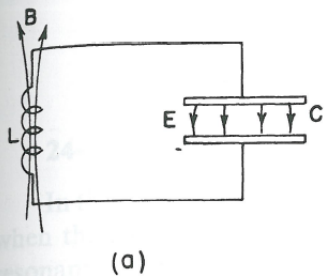
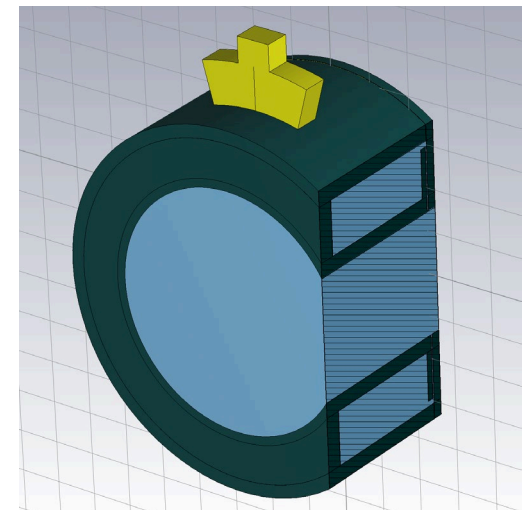

Fig. 23-16. Resonators of progressively higher resonant frequencies.

“The Feynman Lectures on Physics”, Vol.II.

- It is a simple resonant LC system.
- Radiation hard structure.
- In vacuum
- Interception of the particle shower (Target E) and the resulting thermal load causes resonance frequency shift, leading to major calibration issues.



The previous Aluminum MHC5

- Cavity tuned at 101.26 MHz, 2nd harmonic of the beam.
- Water cooling at the beam entry side to minimize temperature excursions.
- But performances worse:
 - Thermal gradient even larger with active cooling
 - Inner part has more deformation than the outer part
 - Leading to larger resonance frequency shifts.

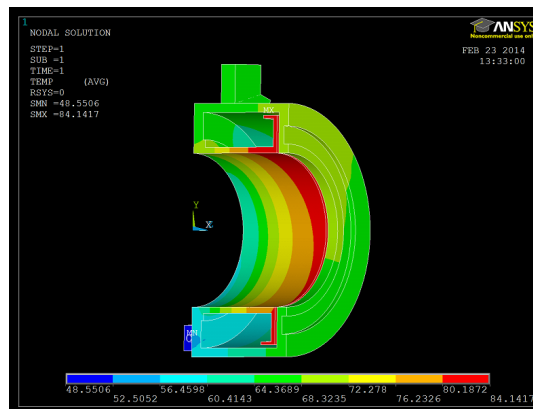
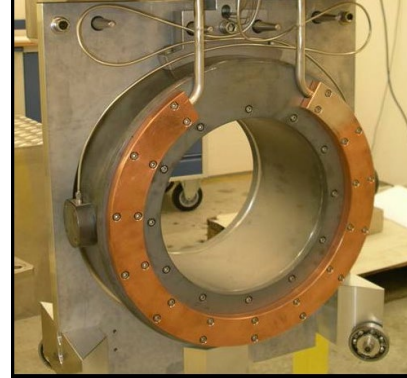

The Graphite MHC₅

- **Advantages of Graphite:**

- Smaller thermal expansion coefficient
- Higher radiation emissivity
- Lower electrical conductivity



Less thermal deformation



Better passive cooling



Lower Q, less sensitive to the frequency shift

- **Increasing the inner diameter to have less energy deposition.**

- **Self-compensation:**

- Place a thin aluminum shim at the capacity gap
- Compensate the gap size when the monitor heated up by the beam, since aluminum has higher expansion coefficient

- **Add-on: four beam position pickups**

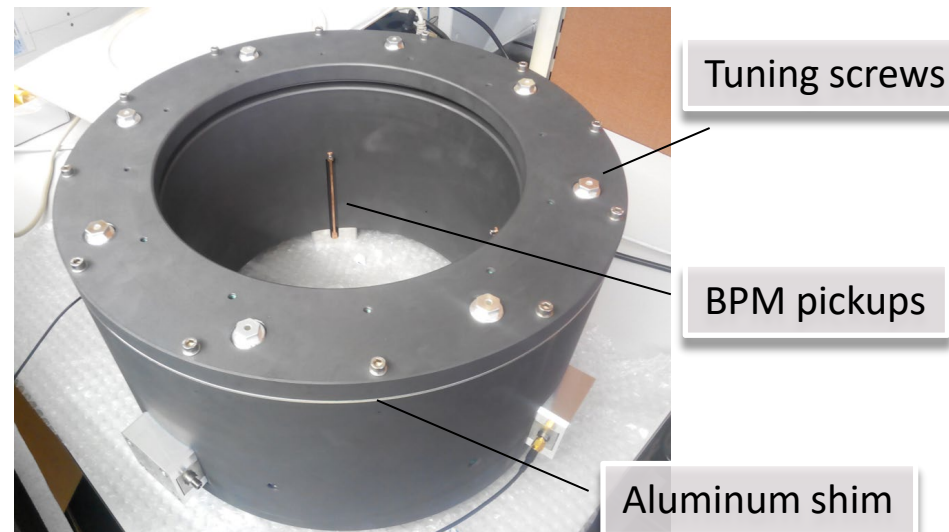
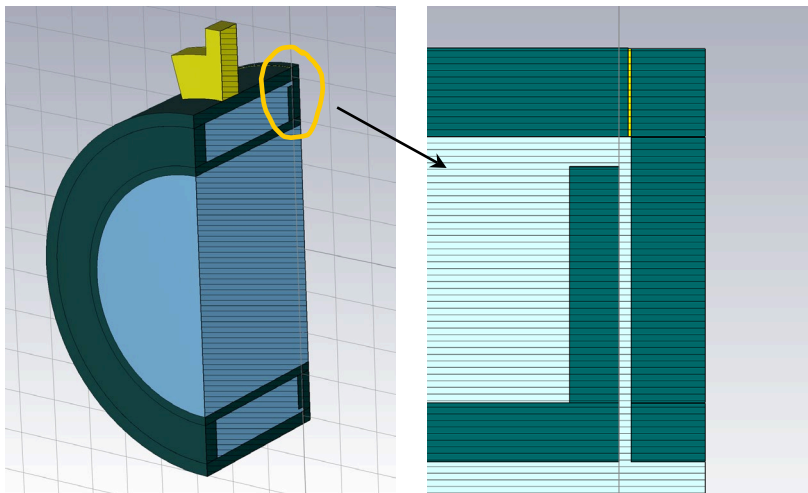

Performance of the Graphite MHC5

- The maximum temperature on MHC5 can up to 120 °C @ 1 MW beam power, still at ~65 °C after beam stopped.
- Deviation between MHC5 and a Bergoz monitor (reference) occurs, when the temperature is moving up and down.
- The Bergoz monitor cannot do 'online' calibration, since the offset of the electronics is drifting.

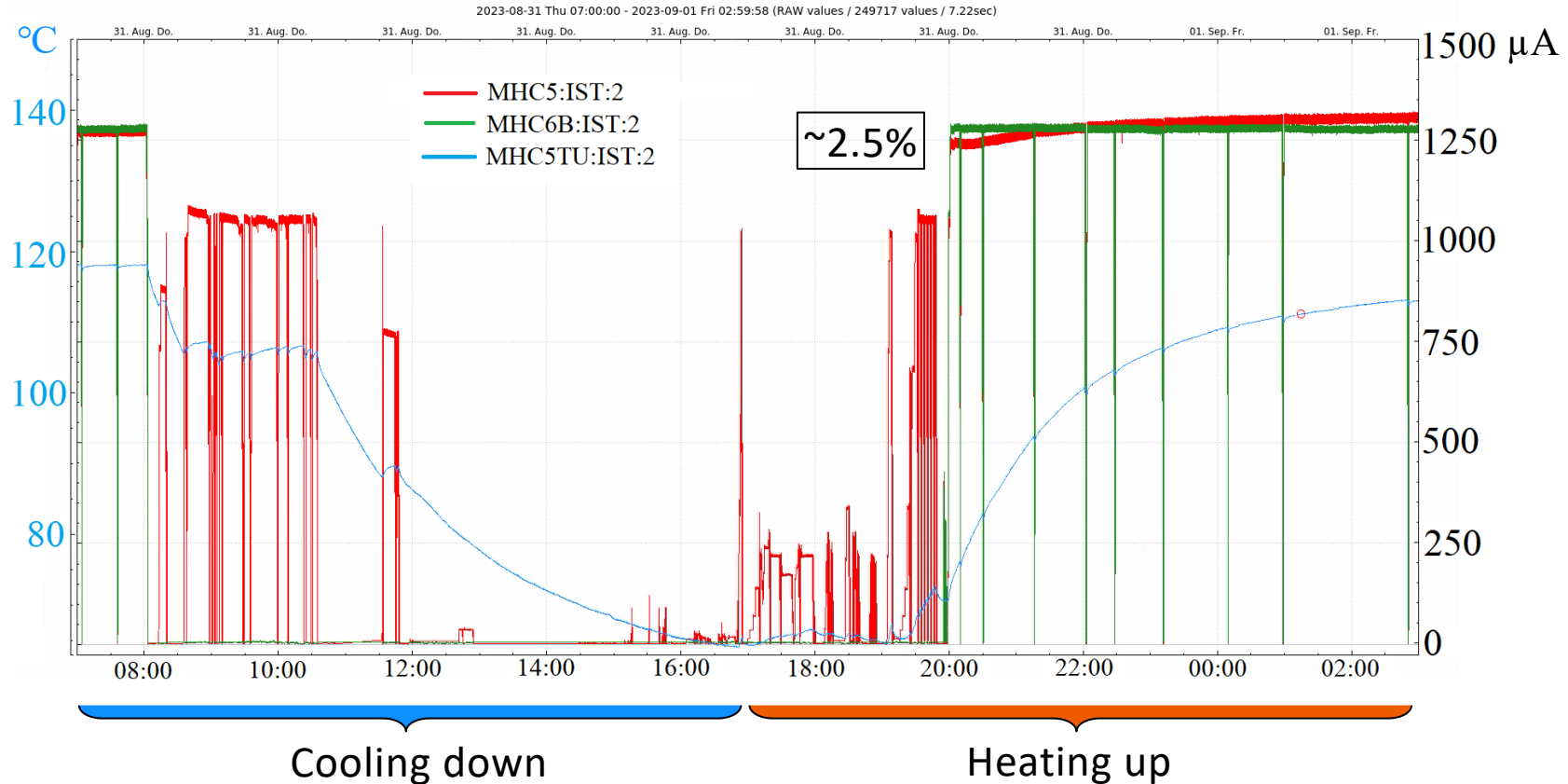

On-line Calibration (1)

- The calibration scheme is based on network analyzer measurements of the resonator transmission at frequencies off the RF frequency band (in our case 600 kHz around 101.26 MHz) to avoid interferences with the beam current measurements.
- The resonator gain is estimated by performing a non-linear fit of the resonance.

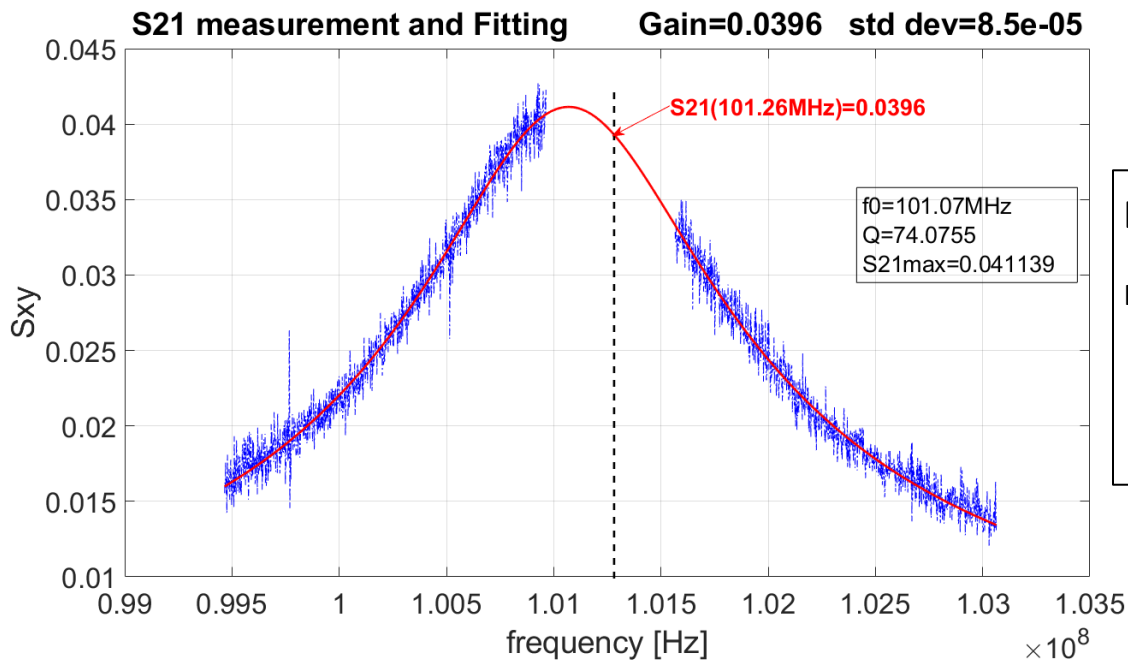

On-line Calibration (2)

- Typical data collected during a service day:
 - The gain is observed to drop from a maximum value of 0.4 to 0.374 (~7% variation) for no beam.
 - The temperature variations due to the modulation of beam intensity are clearly visible as well as the cooling phase in absence of beam.

At each change of the thermal load, the parameter changes are observed first to go in the other direction from the expected one.

This highlights the fact, that temperature measurement alone cannot provide a mean to calibrate the resonator.

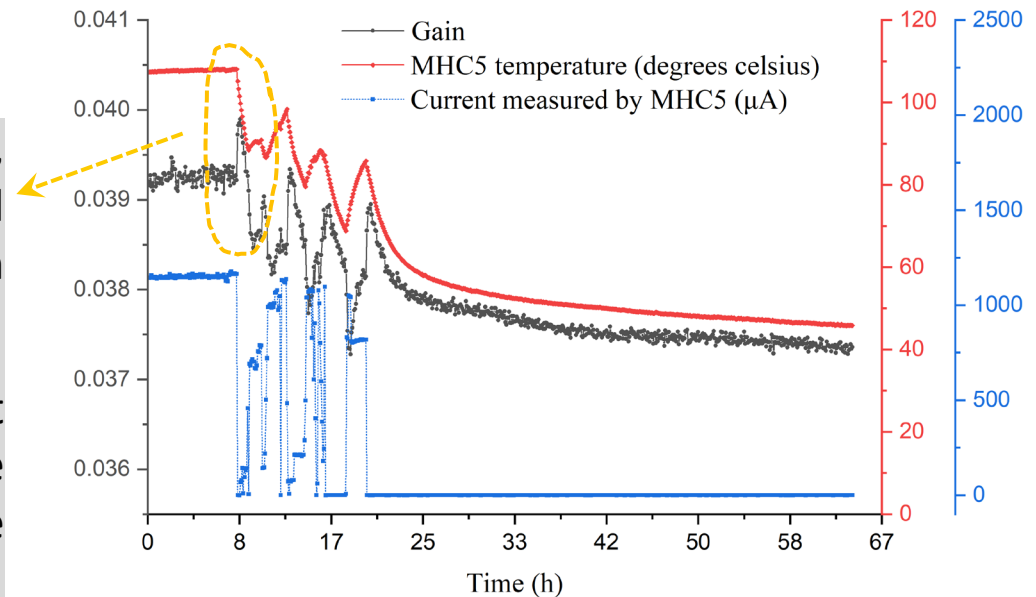

Beam position measurement test

- MHC4 (same type of current monitor located before TE) and MHP41(profile monitor just behind MHC5) are used as references during the beam test.
- The sum value of the 4 pickup shows good linearity with the MHC4.
- (Right-Left)/sum value of MHC5 also shows good linearity with respect to the beam X-center measured by MHP41.

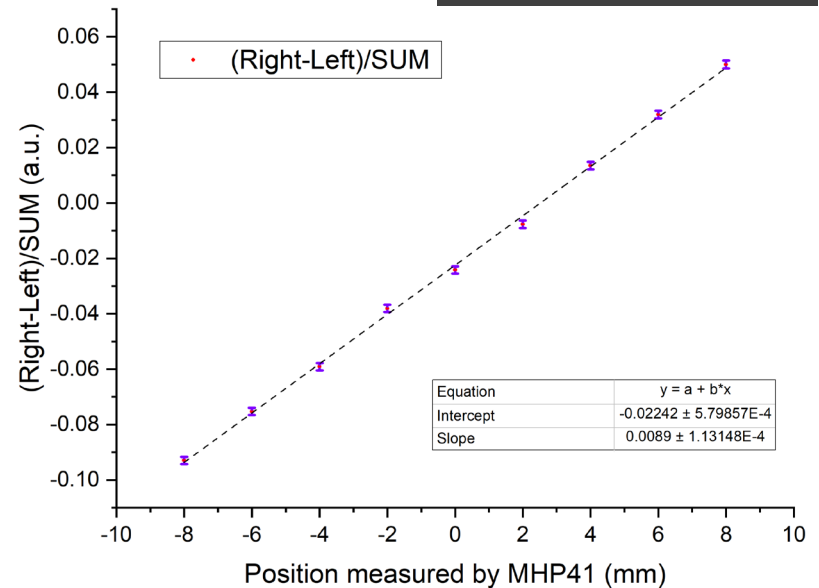
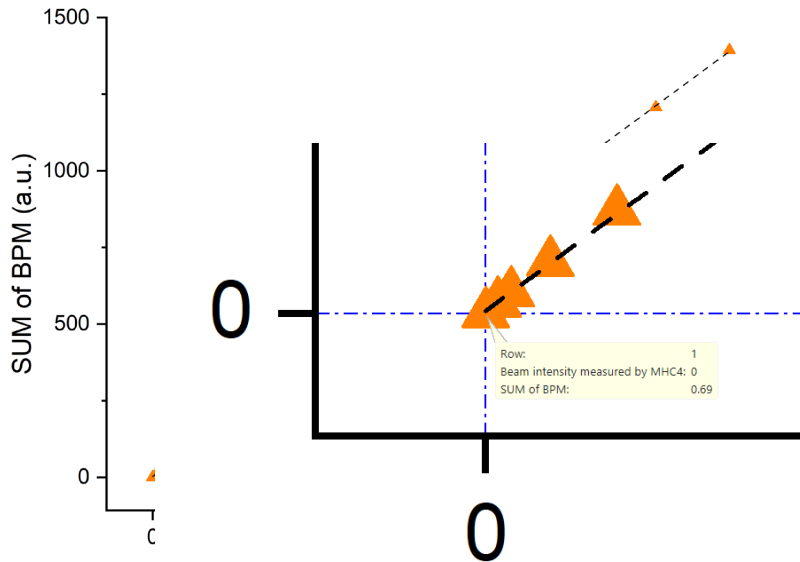
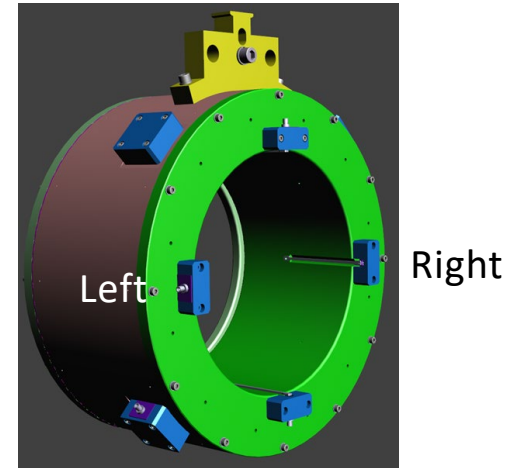

The small positive offset for no beam can be attributed to the instrumental noise.

New design of the BPM pickups (1)

- **Motivation**

- Bunch length measurement
- Beam elliptical measurement

- **Capacitive pickup**

- Good compromise of signal level and pickup length
- Bunch length can be derived from the equation:

$$\sigma_{\text{im}} = \sqrt{\sigma_s^2 + \sigma_{\text{beam}}^2}$$

σ_{im} is the rms length of the image charge on the beam pipe.

$\sigma_s = a/\gamma\sqrt{2}$ is the rms length of the electrical field created by a single charged particle.

σ_{beam} is the rms length of the bunch.

- For the PSI 590 MeV proton beam:

$$\sigma_s = 60.7 \text{ mm}, \sigma_{\text{beam}} = 43 \text{ mm}, \text{ so } \sigma_{\text{im}} = 74.4 \text{ mm (also corresponding to 0.63 ns)}$$

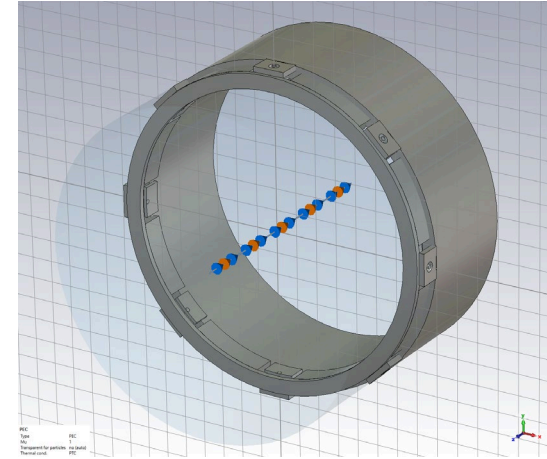

New design of the BPM pickups (2)

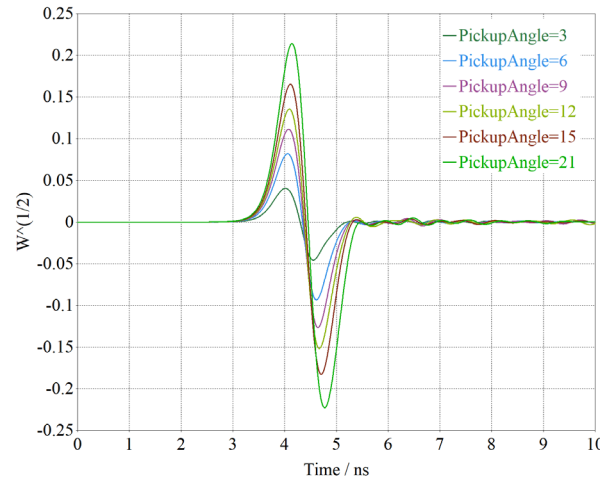
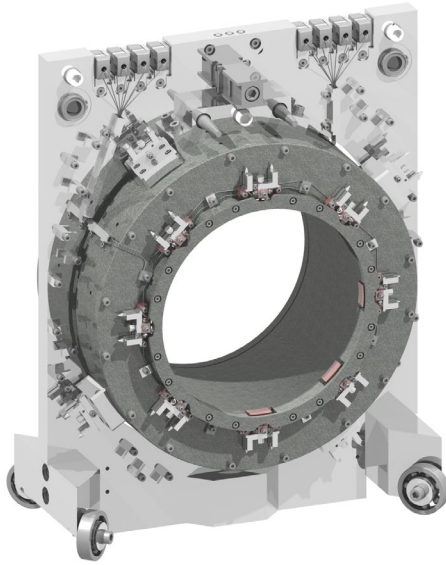

- The pickup dimensions are:
 - 12 degrees aperture
 - 17 mm length

Difference over SUM

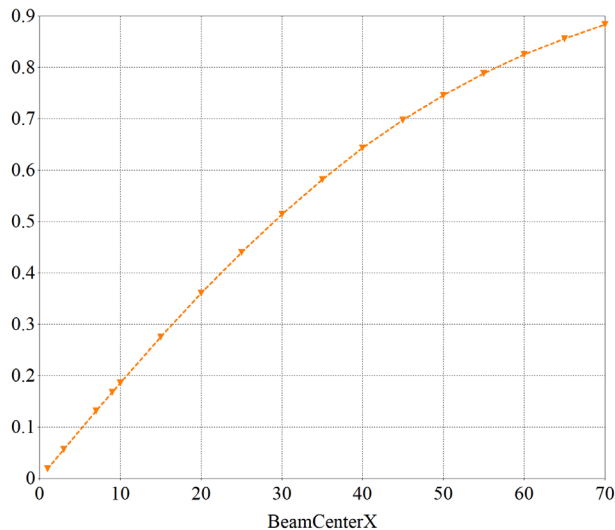

- The pickup response to a Gaussian shaped proton pulse for different angle apertures. The signal amplitude is proportional to the angle aperture.
- Additional structure was designed to improve the isolation between pickups and also for noise shielding.

- While scanning the beam X center from 0 to 70 mm, the ' Δ/Σ ' of two horizontal pickups performs as expected.

New Maintenance features

- Modular design for the new shield instead of a whole big piece.
 - Upper segments reusable
 - Less radioactive waste produced

- Plug in/out type connection allowing the use of the manipulators in case of repairs or maintenance.

- Kapton cables replacing the semi-rigid cables to facilitate the manipulator operations.

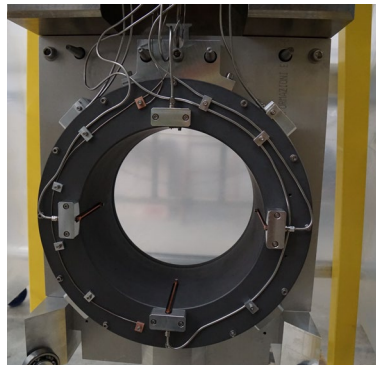
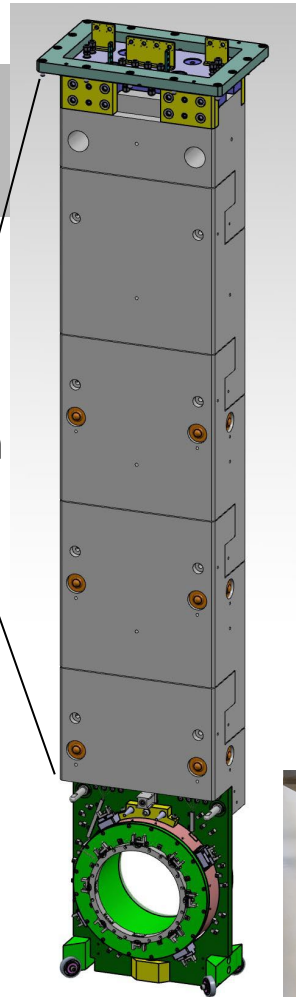
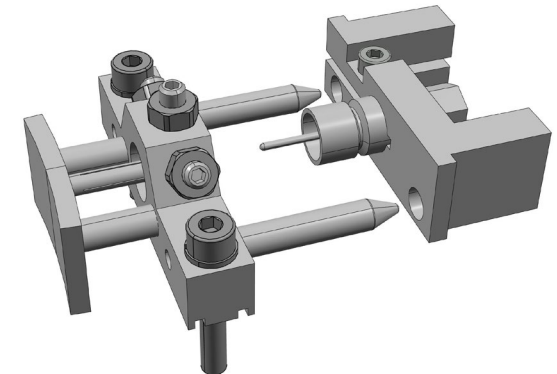
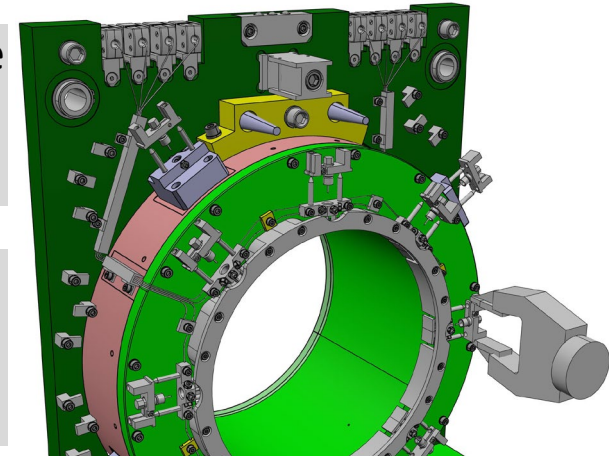
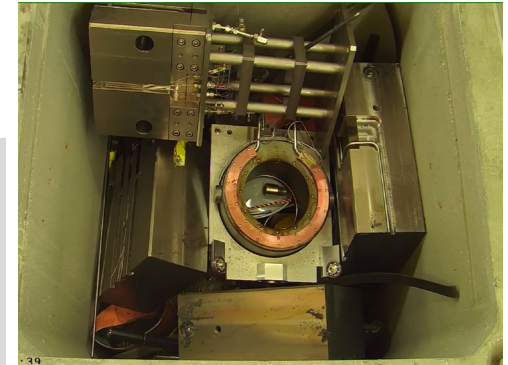

- The graphite resonator version of the MHC5 has been operated under heavy heat load and radiation since 2015.
- Beam current and position measurements are performing as expected.
- On-line current calibration method improves further the stability of the measurements.
- The new MHC5 design will:
 - further broaden the type of measurements performed
 - facilitate maintenance
 - minimize human radiation exposures and active wastes in case of replacement.
- Lab tests with the new system are expected to take place beginning of next year.

Thank you for your attention!

