



FRIB from Commissioning to Operation

Speaker: Peter Ostroumov

K. Fukushima, A. Gonzalez, K. Hwang, T. Kanemura, T. Maruta,
A.S. Plastun, J. Wei, T. Zhang, S. Zhao,

MICHIGAN STATE
UNIVERSITY



U.S. DEPARTMENT OF
ENERGY

Office of
Science

FRIB Layout

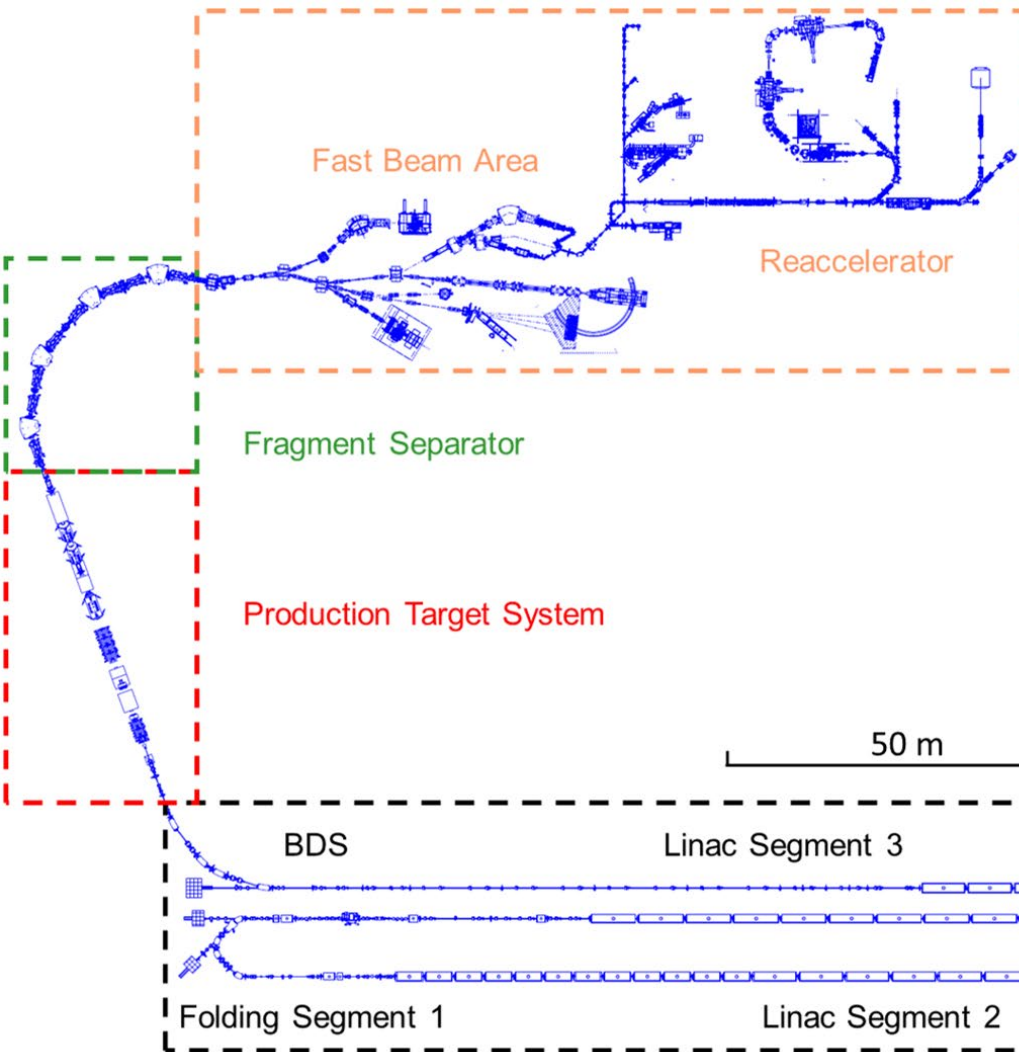

- Linear accelerator
 - 200 MeV/u - U, 320 MeV/u - O
 - CW RFQ, $q/A=1/7$
 - 324 SC cavities in 46 cryomodules
- Fragmentation target/Beam dump
- 2-stage fragment separator
- Fast beamlines
- 6 MeV/u Re-accelerator
- In operation since May 2022
- 12 nuclear science experiments conducted in FY2023

FRIB Accelerator Science and Technology Challenges and Status (1)

Technology Challenges	Status
80.5 MHz CW RFQ for lowest $q/A=1/7$	Operational for a full range of q/A
SRF: mass production of cavities and cryomodules	324 SC cavities of 4 types in 46 cryomodules operate at the design level of gradients +10% margin. Beam focusing with SC solenoids
Large cryogenic facility	Operational with 100% availability
Large SC dipoles, multipole magnets	Four 6 T·m dipoles operational in linac. Two 140 ton and two 110 ton SC magnets, 8 T·m. SC multipole triplets with 30 cm and 40 cm bore
Liquid lithium stripper	Operational, routinely used for high power heavy ions
Digital LLRF for multiple frequencies	Operational. Accuracy of field amplitude is $\pm 0.1\%$ and phase $\pm 0.2^\circ$
Extensive beam diagnostics system	144 BPMs, BCMs, neutron detectors, ionization chambers, wire scanners, temperature sensors on beamline in cryomodules, halo monitors
Machine Protection System	Operational. Response time 35 μs



FRIB Accelerator Science and Technology Challenges and Status (2)

Technology and AP Challenges	Status
Target	Rotating multi-slice carbon disks. Currently: single disk
Beam dump	Rotating thin wall drum filled with circulating water. Currently: static water cooled beam dump up to 20 kW
Two-stage fragment separator	Acceptance: ± 40 mrad, $\pm 5\%$ momentum spread. Pre-separator with momentum compression
Isotope detectors	Fast timing, PPACs, in-flight PID
Multi-q acceleration	Routinely used, reduced beam losses on charge selection slits
High Level Accelerator Physics Applications	Many HLAs in use. New developments including ML to minimize time for machine setting
Uncontrolled beam losses below 10^{-4}	Demonstrated for 17.5 μA argon beam in pulsed mode, 200 kW equivalent. Confirmed for 10 kW CW beams.
Operational challenge: high availability	Multi-prong approach: failure analysis of all devices; spares; preventive maintenance; HLAs for quick setting. 91.5% availability during the first year of operation; AIPs
Future expansion of the facility	There is a space in the tunnel for 400 MeV/u upgrade. A space is available for additional fragmentation or ISOL target.

Staged Beam Commissioning

	Area with beam	Ion species	Beam energy MeV/u	Date	Main goals
1	Front End	Ar, Kr	0.5	July 2017	FE and civil integration
2	First three cryomodules	Ar, Kr	2.2	May 2018	Cryogenic integration, SRF
3	LS1, FS1	Ar, Kr, Xe	20.0	February 2019	104 SRF cavities and stripper
4	FS1, LS2	Ar, Kr, Xe	204 (Ar) 180 (Kr, Xe)	March 2020	2K cryogenics, Linac KPP
5	FS2, LS3	Ar, Kr, Xe	212	April 2021	Linac validation
6	Target Hall	Kr	Rare isotopes	Dec.2021	Project KPP
7	Focal plane of the Advanced Rare Isotope Separator	Ar	210	January 2022	Project completion, readiness for user operation
8	Facility	⁴⁸ Ca	Up to 240 MeV/u	May 2022	Experiments started

FRIB Operation

- Commencement of User Operation – May 2022
- First year of operation
 - Delivered 4252 beam hours at full energy with 91.5% availability and 1000 hours at lower energies, up to 40 MeV/u
 - » Downtime is primarily due to legacy cryogenics system and legacy SC magnets
 - Twelve science experiments carried out and resulted in multiple PRL papers.
 - More than 200 unstable isotopes produced with primary beams of ^{36}Ar , ^{40}Ar , ^{48}Ca , ^{64}Zn , ^{70}Zn , ^{82}Se , ^{86}Kr , ^{124}Xe , and ^{198}Pt accelerated up to 240 MeV/u
- Both primary and secondary beams are extremely stable during the experiment

Dual charge state $^{64}\text{Zn}^{28+,29+}$ for experiment, 150 hrs

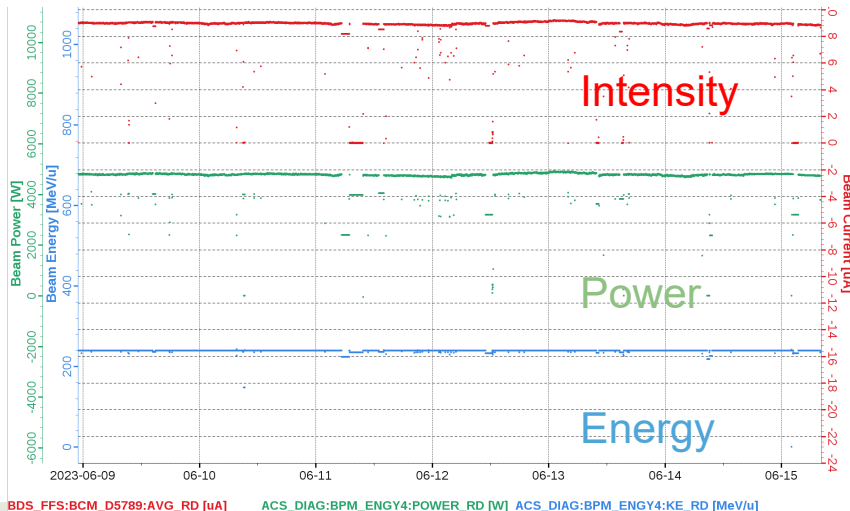

>200 unstable isotopes

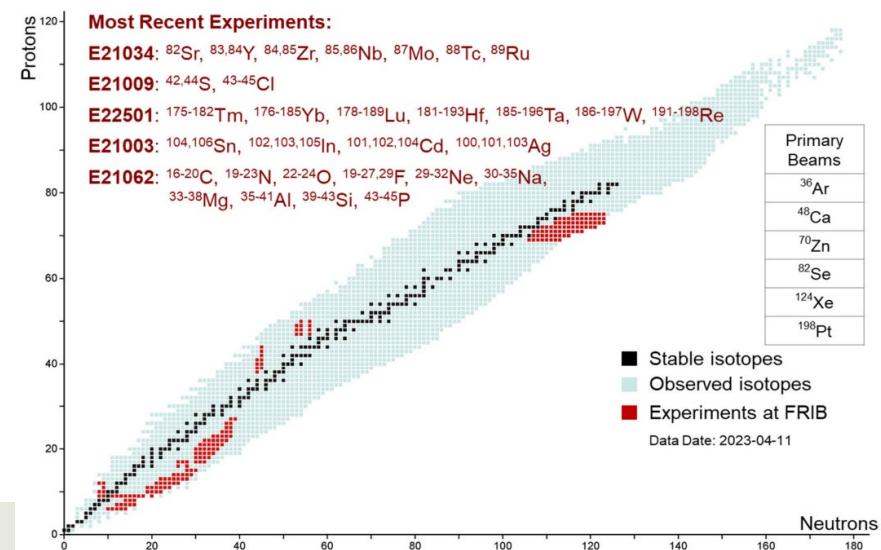

Facility for Rare Isotope Beams
 U.S. Department of Energy Office of Science
 Michigan State University

Focus of Accelerator Physics

- **Develop new heavy ion beams**
 - Reduce radio-activation of the charge selector by acceleration of multiple charge state beams starting from dual charge state ^{48}Ca
 - Maintain uncontrolled beam losses below 10^{-4}
- **Shorten the accelerator start-up time to provide more beam time for science**
 - Typically, the experiments with a specific species of rare isotope beam last a week or two. Each experiment requires a different primary beam species with specific energies.
- **Prepare and increase beam power on-target according to 6–year plan**
 - Gradual power increase as stipulated by the Operational Safety Envelope
- **Prepare for the ultimate 400 kW operation**
 - Identify possible sources of uncontrolled beam losses and develop preventive measures
 - Our studies show that SRF cavities' performance is sensitive to the beam losses and cannot tolerate 1 W/m losses. Possible consequences: field emission and performance degradation.
 - Develop 2q Uranium acceleration to the stripping energy 17 MeV/u



Front End

- FE is designed to extract, transport and accelerate dual charge state heavy-ion beams
 - All ion species and charge states extracted from the ECR and accelerated by HV platform voltage
 - Beam space charge and neutralization are significant only before the charge selection slits located after 90-deg magnet
- Beam halo is collimated in the phase space by two round apertures by removing 5-10% particles
- Beam centroid (6D vector) deviation in MEBT from previously saved setting
 - A few mm position and a few degrees of phase deviations in MEBT BPMs
- Bayesian optimization is used to tune the 6D vector
 - Tuning the highest transmission, close to 100%, through the RFQ facilitates optimization
 - » RFQ is designed for small longitudinal emittance and 80% transmission

Front End: 2 ECRs,
LEBT, RFQ, MEBT
500 keV/u $1/2 \geq q/A \geq 1/7$

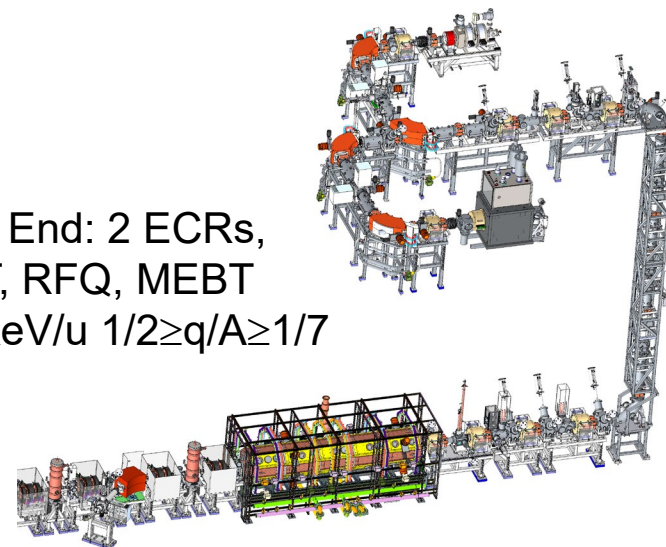

Beam profiles in the MEBS with and w/o
2 collimators in LEBS

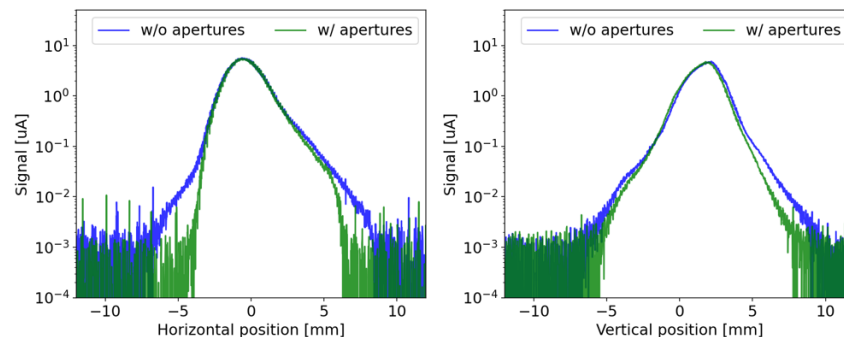

Charge Stripping and Multi-Q Acceleration

- Increase heavy ion beam power on the target with available intensities from the ion source
 - Factor of 2.5 for 3q Xe and 5 for 5q U compared to single charge state
- Significantly reduce power deposition on the charge selection system at stripping energy 17-20 MeV/u
 - Reduced radioactivation in the middle of the linac tunnel
- Beam bends are achromatic and isopath: unity transformation in 6D phase space independently from charge state
- Adds additional challenges for the beam tuning
 - Maintain minimal beam misalignment transversely independently from charge states
 - Large longitudinal acceptance

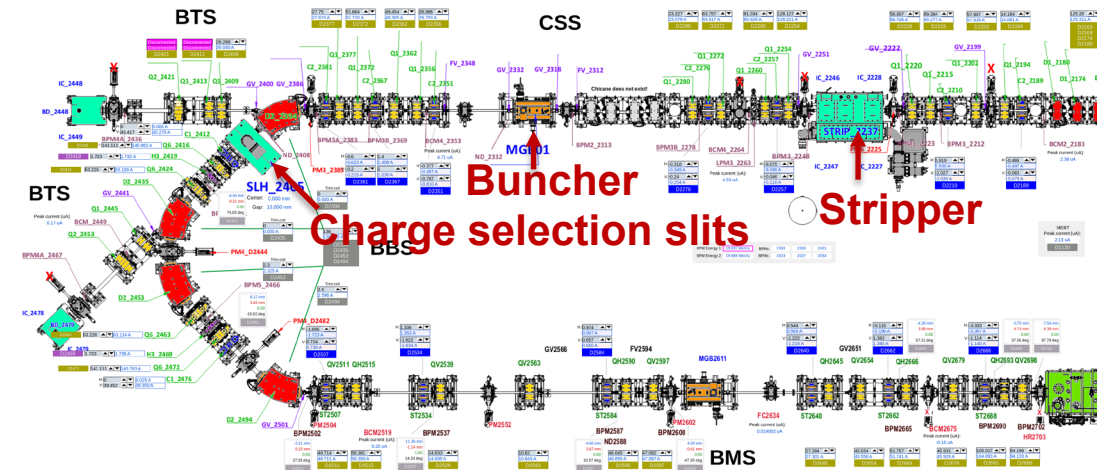
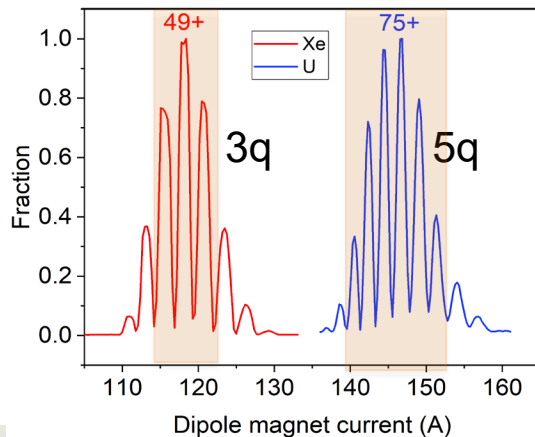

Rotating Carbon Foil up to 10 kW Beam on Target

- Routinely has been used to run user experiments with 5 kW beams on-target
- Suitable up to 10 kW on-target for majority of ion species lighter than Xenon
- Requires ~3 hours of conditioning for outgassing
- Rotation speed 100-150 rpm
- 1 mg/cm²

Foil thinning is fast during the conditioning and slow during operation

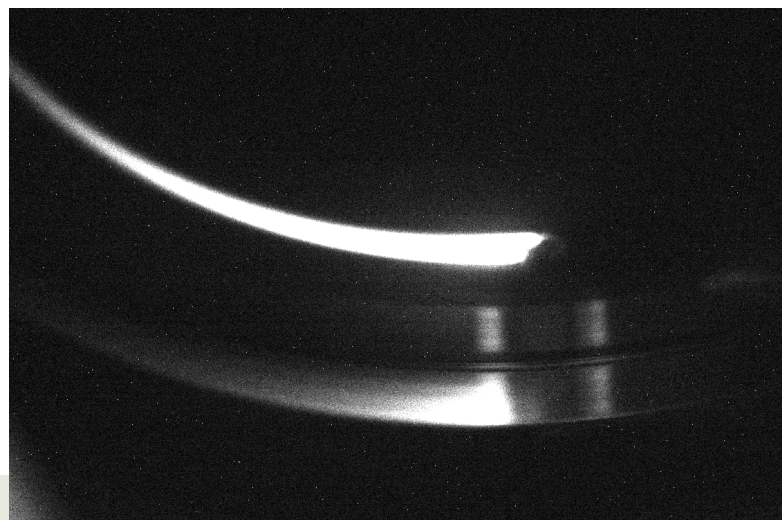
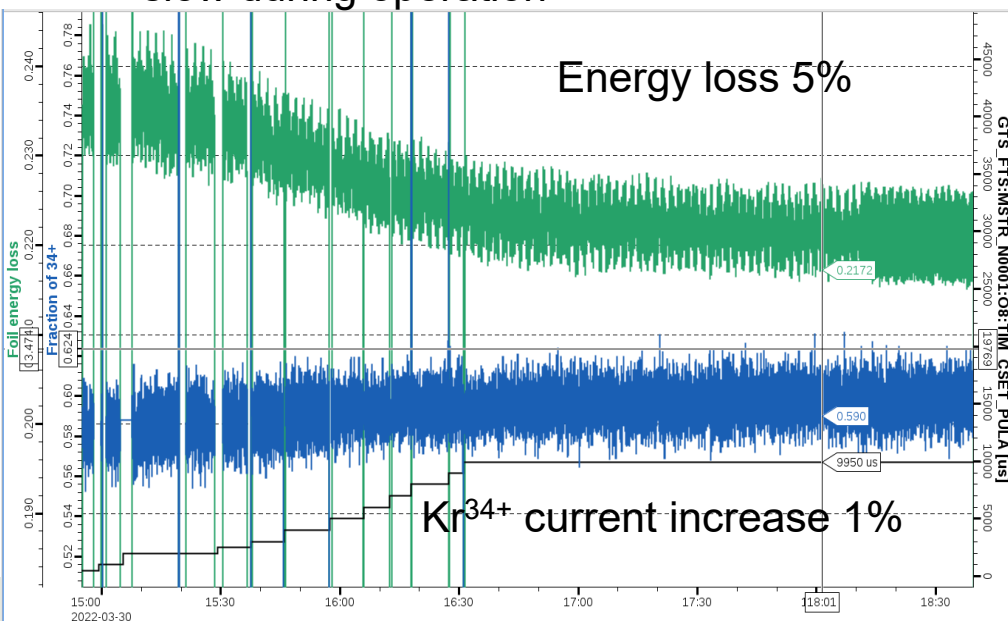
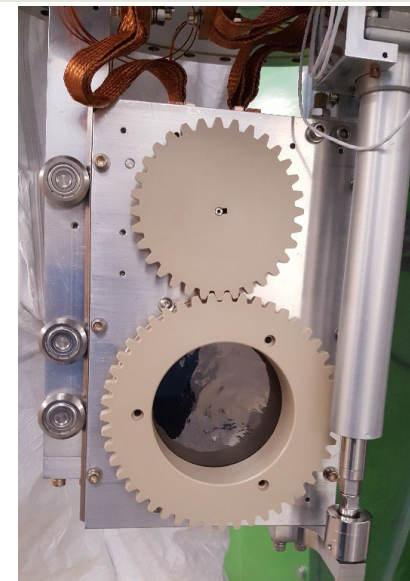

Liquid Lithium Film Stripper

- Liquid metal is efficient for stripping high-power ion beams

Beam emittance increase due to scattering and energy straggling	Short bunch and small beam size on the film
Non-uniformity of the film results in increase of the momentum spread	Small beam size on the stripper $< 0.5 \text{ mm rms}$
Instabilities of the film thickness	Feedback for beam energy and arrival time to the buncher

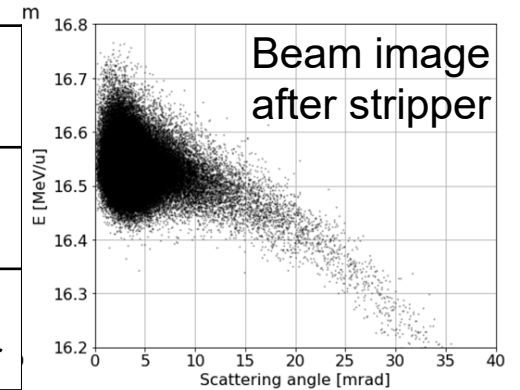

Xenon beam on Li film

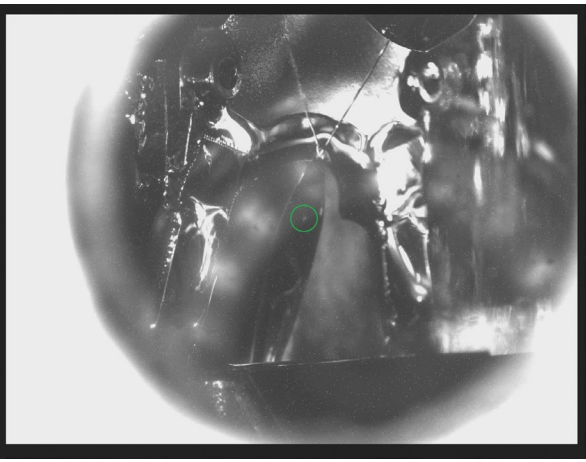

Film thickness

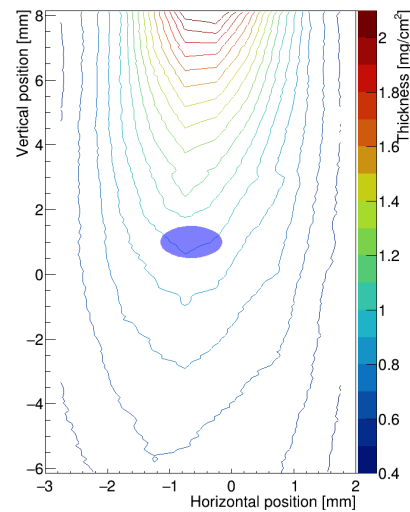

Beam energy feedback

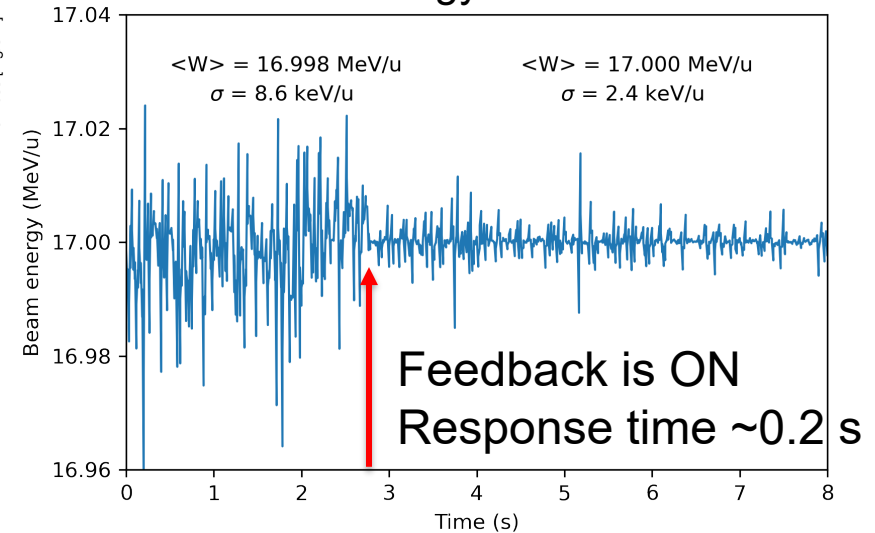

Future Improvements for High Power Operation

- Reduce beam size on the stripper to $\sigma \sim 0.3 \text{ mm}$
 - Replace 8 quadrupoles with larger aperture quads
 - Collimate large-angle scattered ions immediately after the stripper
- Add the second harmonic cavity to improve linearity of the bunching voltage and increase the acceptance of the following accelerator section
- Increase film thickness

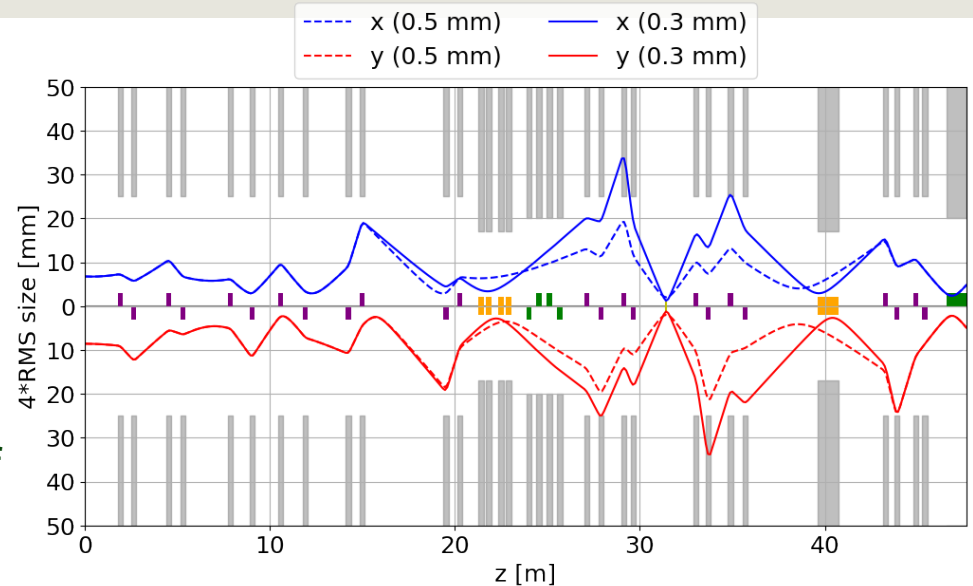
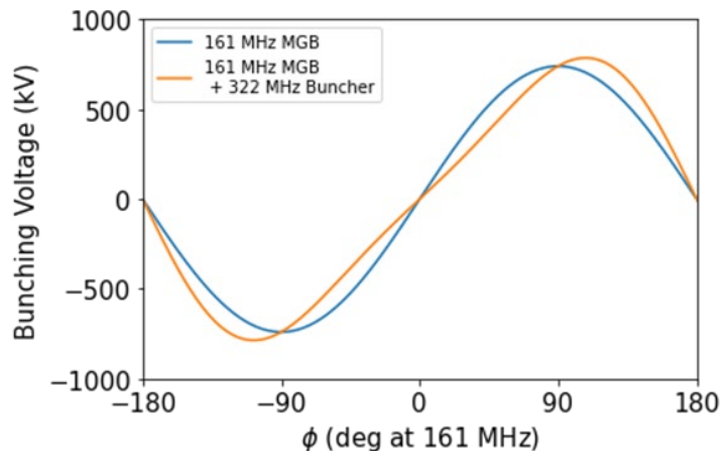

Acceptance of 3q Xe beam w/o (left) and with (right) second harmonic cavity

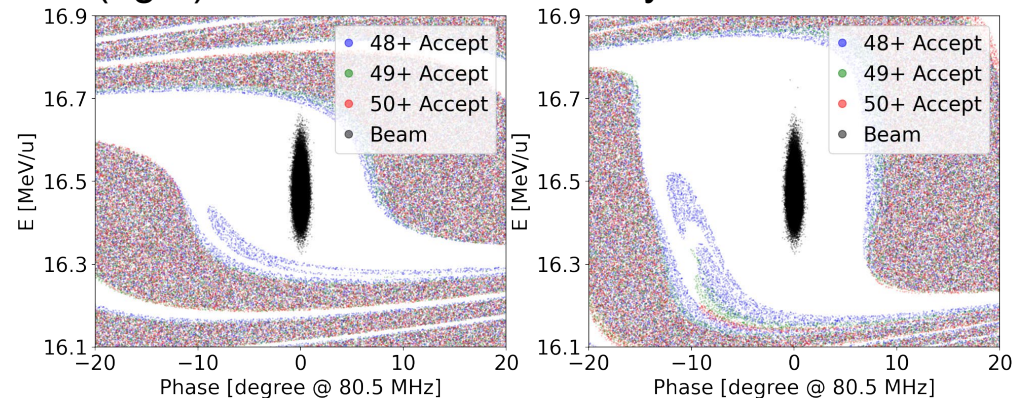

FRIB Controls and High-Level Applications

- Typically, the experiments with a specific species rare isotope beam last a week or two. Each experiment requires a different primary beam species with specific energies.
 - To increase beam hours for science the Linac and ARIS setting must be developed fast
- FRIB uses EPICS. For the HLAs we use Python and Qt.
- Most frequently used applications
 - Setting manager
 - Optimization of 6D bunch centroid in FE
 - Instant phase setting
 - Beam steering correction
 - Evaluation of Courant-Snyder parameters by profile measurement and Q-scan
 - Transverse matching
 - Longitudinal envelope mapping
 - Device viewers (BPMs, BLMs, BCMs, ND)

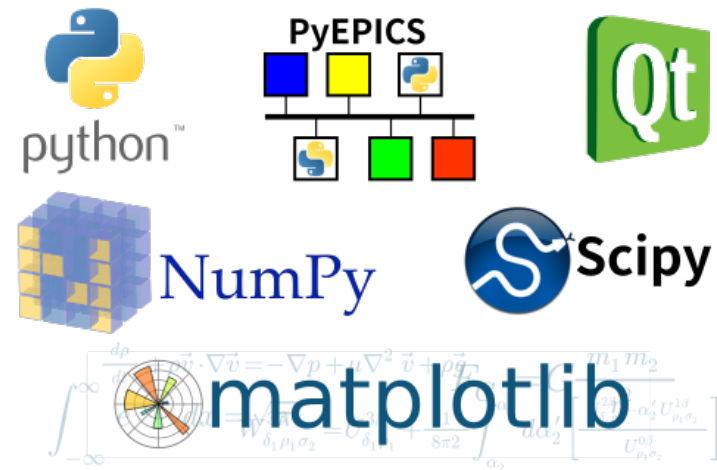

Task	Hrs
Restore light ion (single charge state) beam	16
Restore heavy ion multi-q beam	24
Develop new light ion beam	32
Develop new heavy ion multi-q beam	42

Instant Setting of RF Phases/Amplitudes for Linac Segments

- Static phase shifts in RF transmission/amplifier lines and BPMs' cables were calibrated by the beam of known velocity

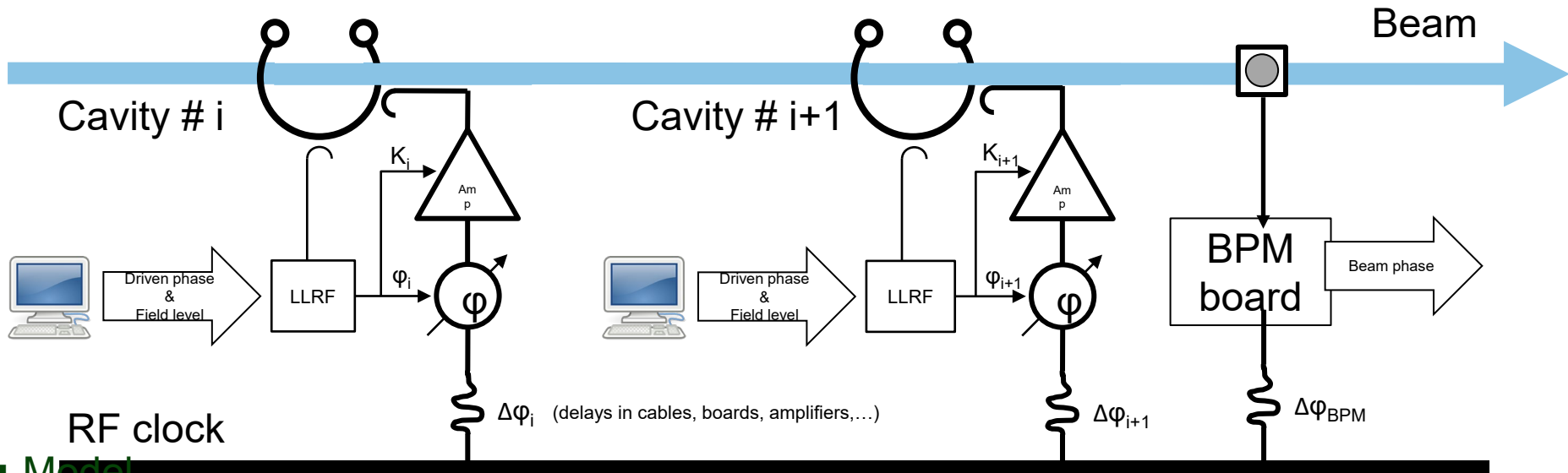

Model

Cavity field: $E_i = K_i E_0 \cos(2\pi f t + \Delta\phi_i + \phi_i)$

$$\begin{cases} \frac{dW}{dz} = qE_z(z) \\ \frac{dt}{dz} = \frac{1}{v_z} \end{cases} \quad E_z(z) = \begin{cases} K_i E_i(z) \cos(\omega t + \Delta\phi_i + \phi_i), & z_{i0} < z < z_{ie} \\ 0, & z_{(i-1)e} < z < z_{i0} \end{cases}, i = 0 \div N$$

Longitudinal Envelope Mapping

- IPS application relies on maintaining RF calibration unchanged.
- Unknown change in calibrated phase shifts results in wrong longitudinal dynamics
 - One or two errors are not critical for 1q beams but may result in beam losses for multi-q beams
- Envelope mapping helps to reveal the errors if the phase shift calibration is lost

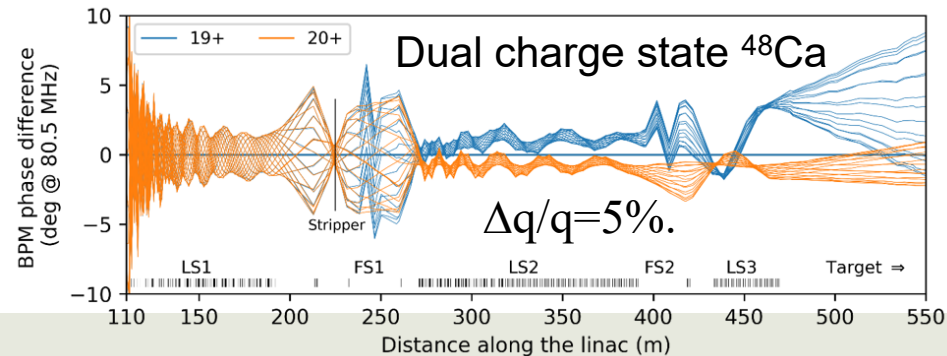
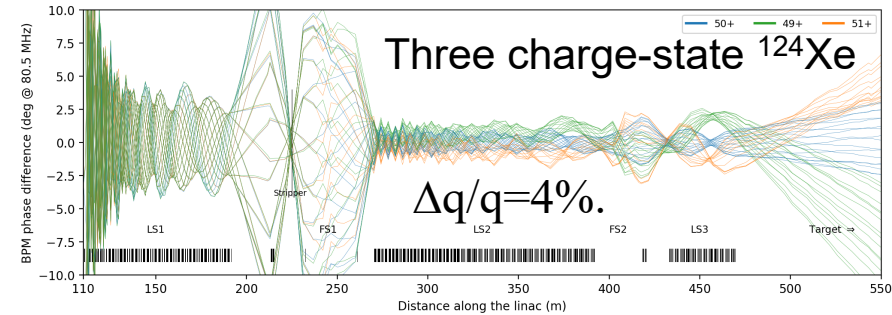
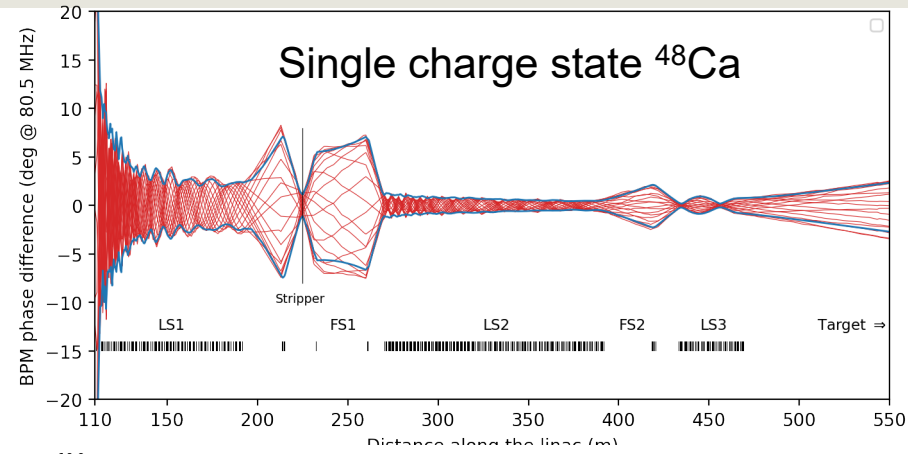
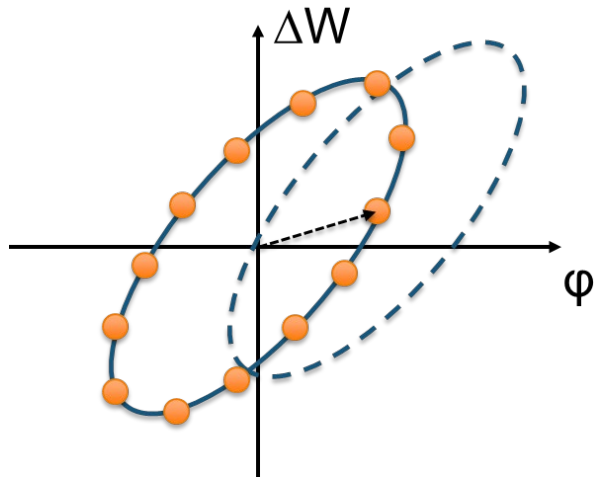

Matching in Transverse Phase Space

- Accelerator setting is calculated with the second-order envelope code
- Beam parameters measurements and matching
 - LS1, match into solenoidal focusing channel;
 - Stripper, obtain required beam rms size on the stripper
 - FS1, match into the 180-deg achromatic bend;
 - LS2, match beam into solenoidal focusing channel;
 - FS2, match into the 180-deg achromatic bend;
 - LS3, match to the focusing channel;
 - BDS, form the required beam size on the target.

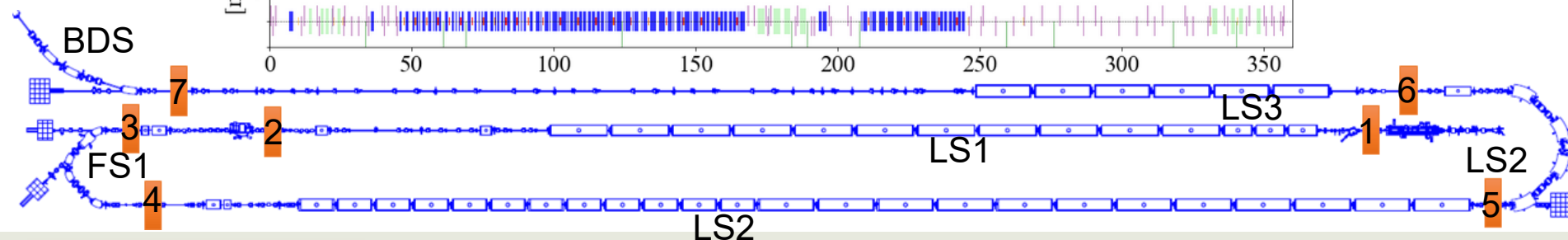
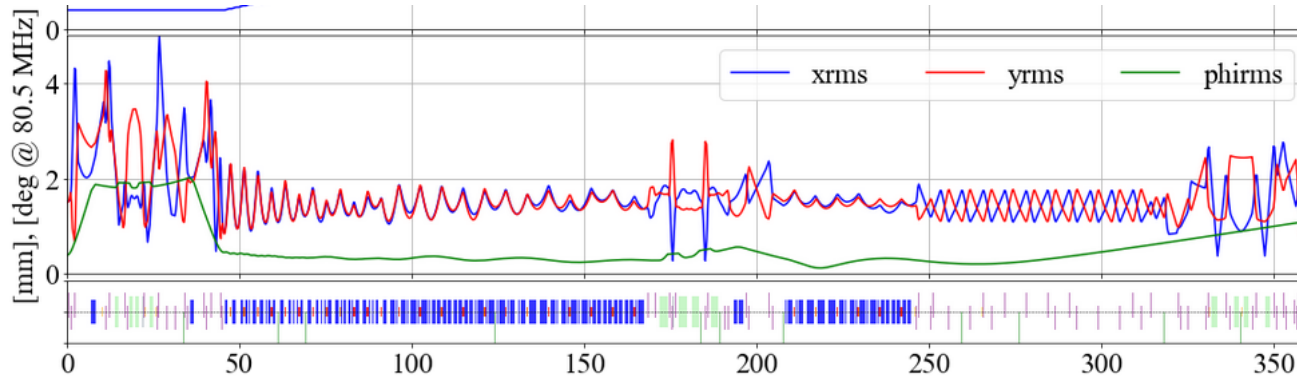

Multi-q Beam Tuning Through Achromatic Bends

- Alignment of the transverse position of the central charge state q_0 in each quadrupole by varying fields in the bending magnets.
- Sextupoles are off. Tuning charge states $q_0 - 1$ and $q_0 + 1$ to the same transverse position after the bend by varying quadrupoles' settings to achieve the achromatic bend
 - Transverse offset of $q_0 - 1$ and $q_0 + 1$ is not zero due to the second-order effects
- Tuning of sextupoles and quadrupoles to minimize the position offsets between all charge states
- Similar procedure is applied for two-charge-state beams
 - Difficulty is the absence of the central charge state
 - Align first the highest intensity charge state

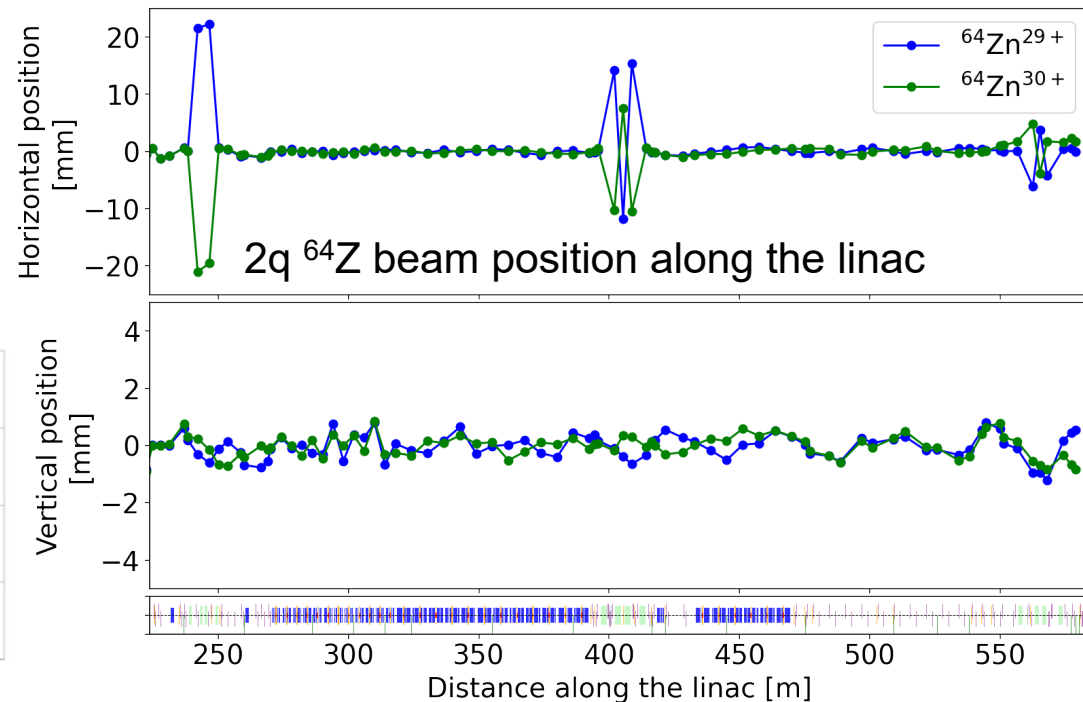
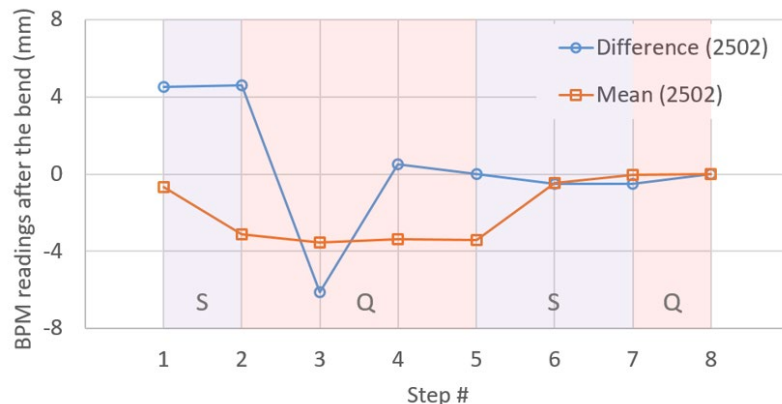

Beam Delivery to Target

- 99% of 1q or multi-q beam is focused to 1-mm diameter spot on target

Non-distractive transverse envelope mapping to verify beam parameters on target

Matching of 3q beams

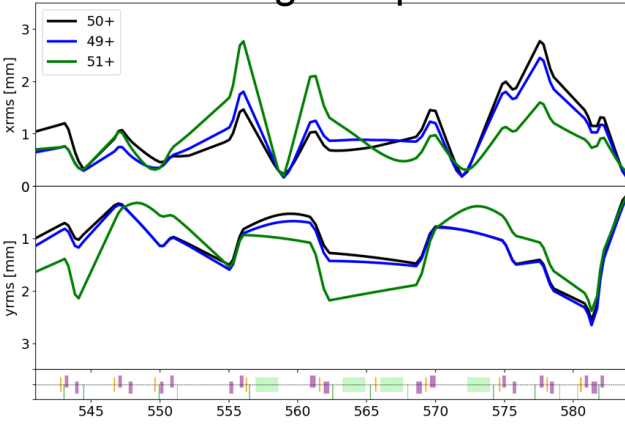

3q Xe beam thermal image on static target

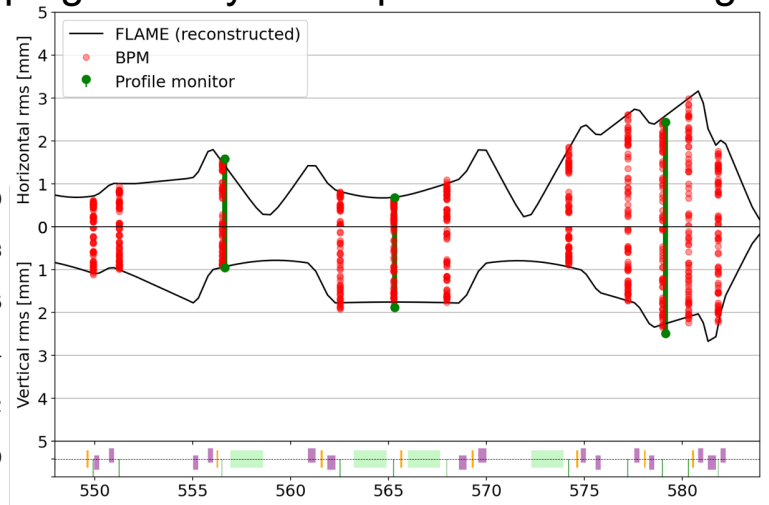
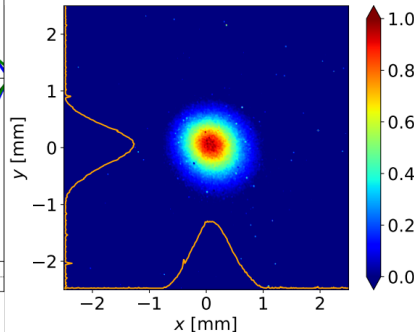

Segmented collimator 1.5m upstream of target



Beam position adjustment based on temperature sensors

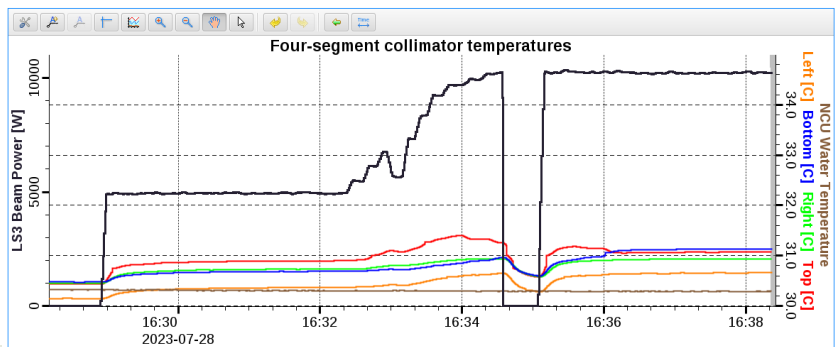

10 kW beam thermal image on rotating (500 rpm) target

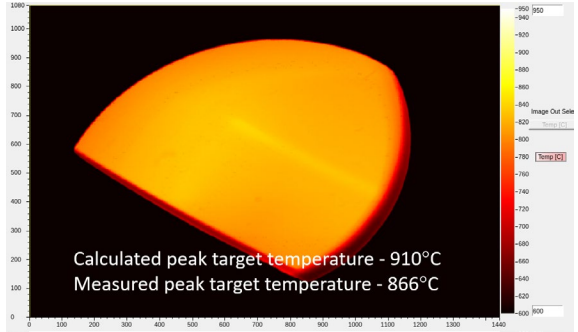

Beam Emittance and Losses

- Typical rms emittances measured for ^{124}Xe beam, single and multi-charge
 - LEBT apertures significantly reduce rms emittance
 - Beam size is larger on C-stripper, larger emittance growth
 - Lithium stripper results in smaller emittance growth due to smaller beam size
- Beam losses in LS2 are measured by calibrated thermal sensors are $\sim 10^{-5}$
- Measureable beam losses during the operation: stripper, charge selector and BDS
- Residual activation after one year of operation and 10 days cool down

RMS emittance [$\pi \cdot \text{mm} \cdot \text{mrad}$]

Date/Strip		MEBT	FS1	LS2	FS2	LS3	BDS		
2/16/23		26+							
C, 1 mm, rms w/o apertures	X	0.136	0.084						
	Y	0.117	0.131						
4/7/23		26+	26+	50+	50+	50+	49+	50+	51+
C, 1 mm, rms w/ apertures	X	0.034	0.036	0.109			0.094	0.114	0.219
	Y	0.03	0.026	0.95			0.12	0.108	0.14
4/22/23		26+	26+	49+	49+	49+	48+	49+	50+
Li, 0.35 mm, rms w/ apertures	X	0.035	0.038	0.063	0.064	0.067	0.127	0.071	0.076
	Y	0.05	0.033	0.041	0.052	0.052	0.064	0.063	0.118

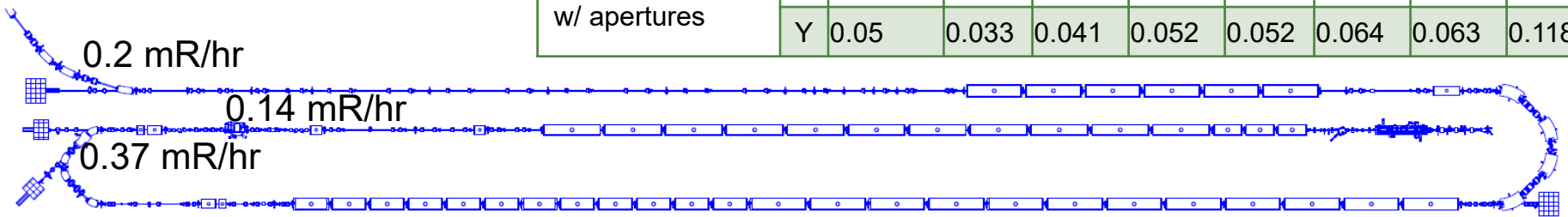

Beam Status in the Linac for Operators

- After the completion of the reference tune, the operators can observe beam status in the linac using the signals from 144 BPMs

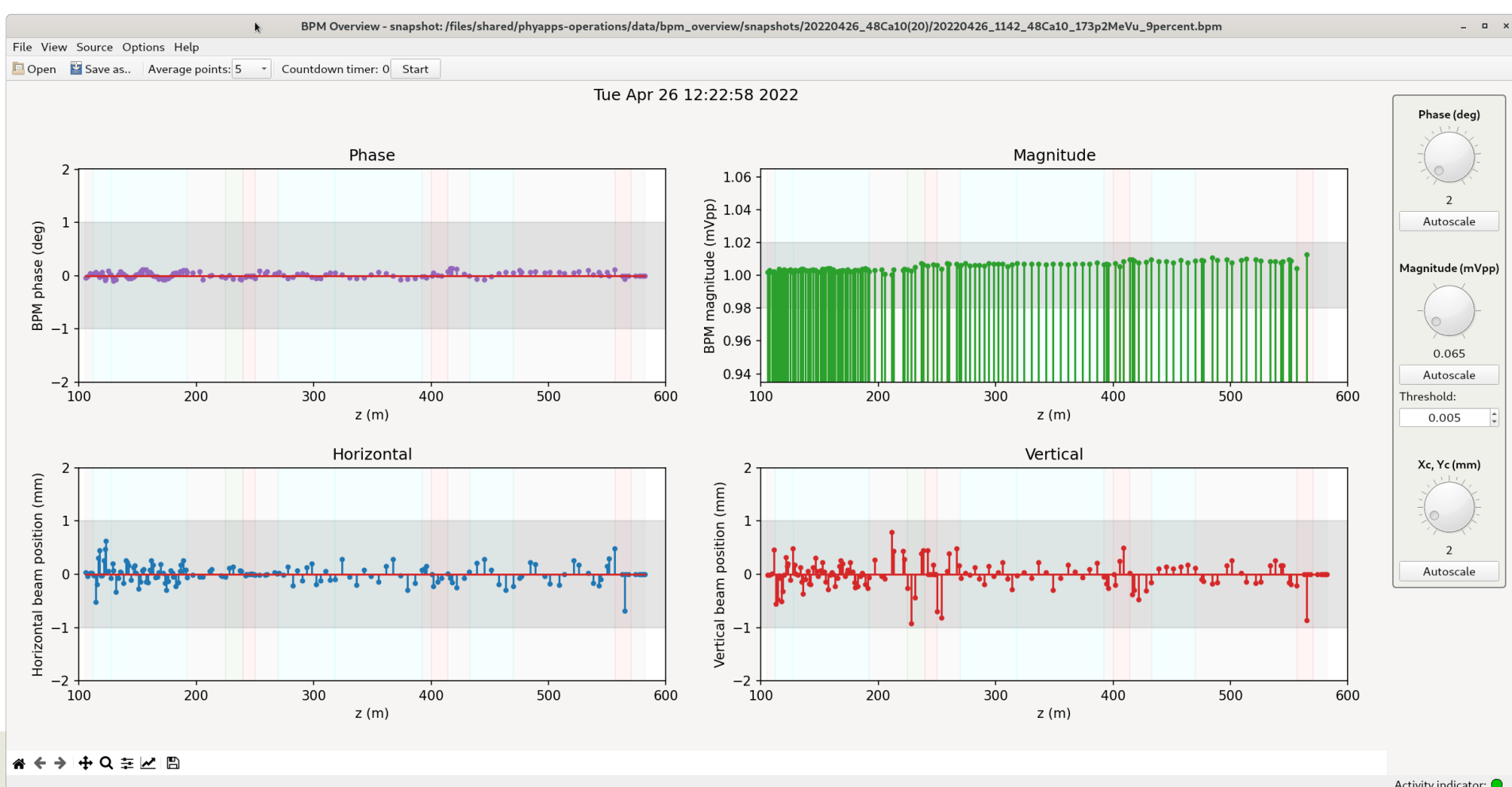

Summary

- FRIB provided 4252 beam hours in FY23 with 91.5% availability
 - Additional 1000 hours were provided for Single-Event Experiments at lower energy
- The beam power of the linac has been increased 10-fold within 1.5 years up to 10 kW
 - There are presently about 45 approved experiments requesting 10 kW primary beams
 - Higher power, 20 kW ion beams will be available in FY2025.
- The liquid lithium stripper is operational
- Multiple charge state beams are routinely used to deliver required beam power on target at reduced beam losses on the charge selector
 - In addition to three-charge-state ion beams, a dual charge state Zn beam was developed and used for science experiments.
 - The linac tune for the acceleration of dual charge state ^{48}Ca beam with the most challenging charge spread of 5% has been demonstrated.
- Accelerator improvement and R&D projects are ongoing toward 400 kW beams
- More FRIB reports in Working Groups by Drs. Jie Wei and Takauji Kanemura

BACK UP SLIDES



Facility for Rare Isotope Beams
U.S. Department of Energy Office of Science
Michigan State University

Radio Frequency Quadrupole

- Unique parameters:
 - CW
 - Maximum voltage is 112 kV
 - Variable R_0 and voltage
 - $q/A=1/7$
- Conditioned at the design voltage
 - Tested with uranium beam



Frequency (MHz)	80.5
Injection/Output energy (keV/u)	12/500
Beam current (typical, μA)	450
Beam emittance (full, norm, $\pi\mu\text{m}$)	1.0
Long. Emittance (99.9%, keV/u-ns)	1.5
Transmission efficiency (typical, %)	80
Design charge-to-mass ratio	1/7-1/3
Accelerating voltage ramp (U, kV)	60 – 112
Surface electric field (Kilpatrick)	1.634 (CST)
Quality factor	16500
Operational RF power (kW, O-U)	15 – 100
Length (m)	5.0

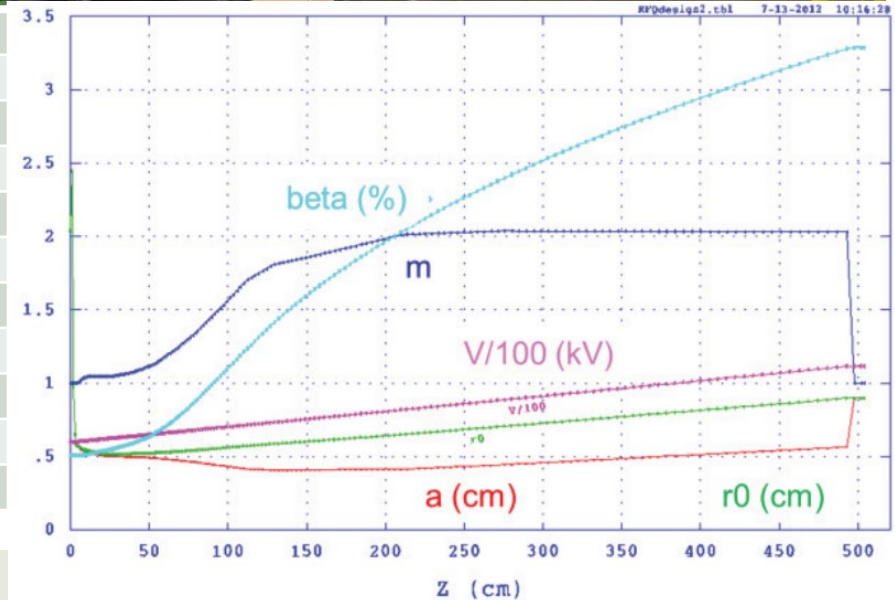

Superconducting RF

- Challenge: mass-production of 324 SC resonators and 46 cryomodules with required accelerating gradients and specified limit of the heat load
 - This task was successfully accomplished
- FRIB cavity specifications are modest: $E_{\text{PEAK}} \cong 30$ MV/m, $B_{\text{PEAK}} \cong 60$ mT
 - All cavities exceeded the specifications
 - About 10% higher accelerating gradients are available from the majority of cavities

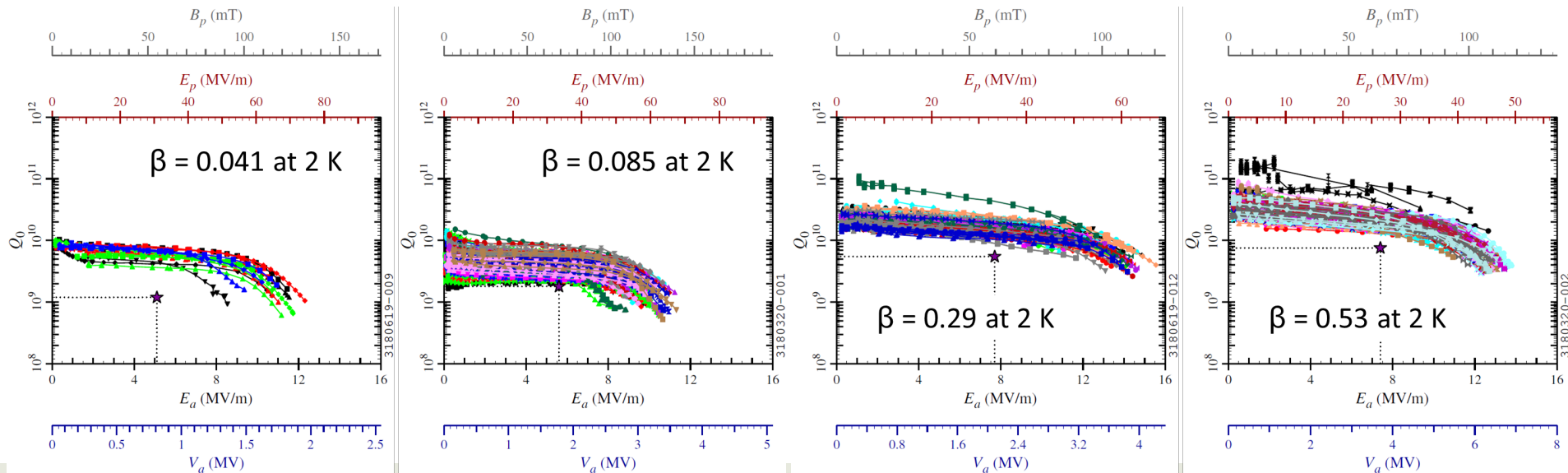

SRF Cryomodules

Example of cryomodules' cold mass
 $\beta = 0.53$



$\beta = 0.085$



Cryomodules include
SC magnet assembly
of solenoid and dipole
coils

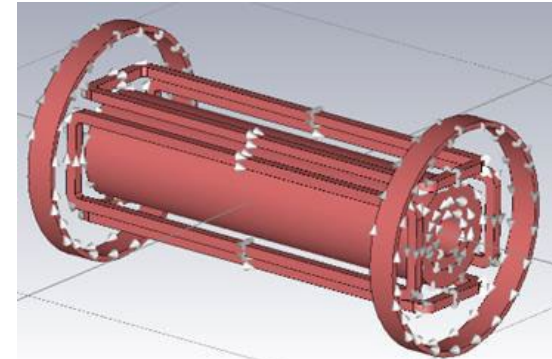

All 46 cryomodules installed in the tunnel and
are being used for beam acceleration



^{36}Ar , ^{86}Kr and ^{129}Xe Accelerated above 200 MeV/u

- Three-charge-state $^{124}\text{Xe}^{49+,50+,51+}$ and two-charge state $^{86}\text{Kr}^{33+,34+}$ were also accelerated and delivered to the beam dump with 100% transmission

Phasing of SC cavities
Beam energy vs time

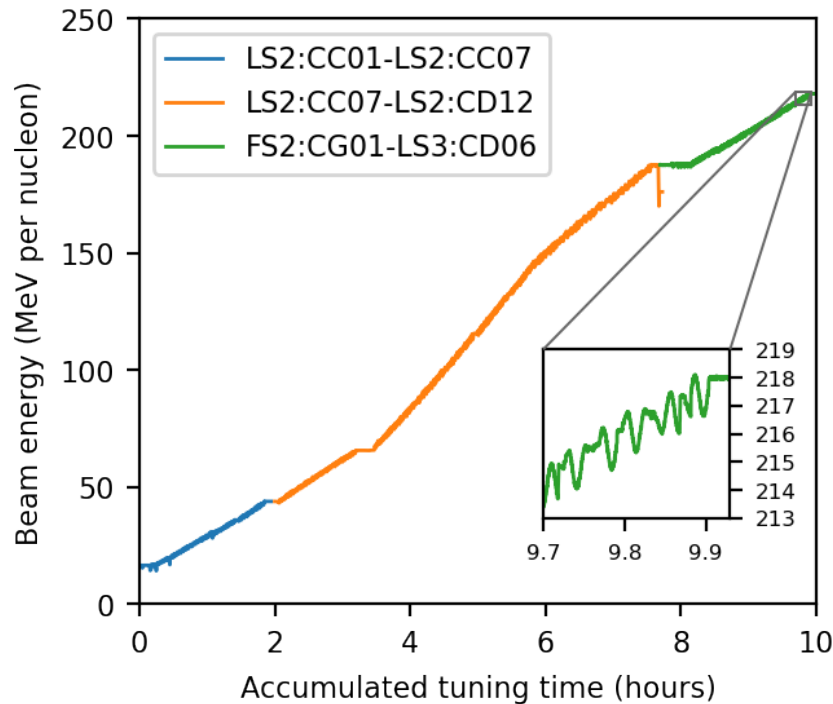

Transmission of ^{36}Ar , beam current in μA

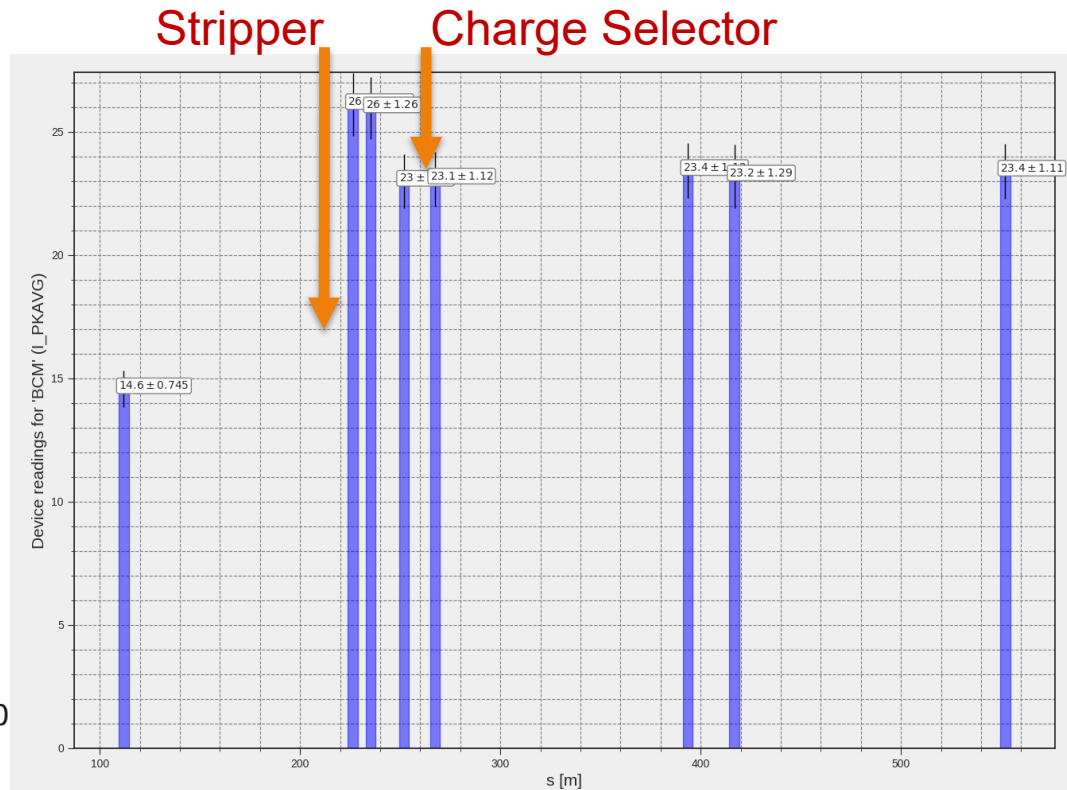

Trajectory Correction

Extending to Tune the Entire Segment by One Knob

- Trajectory Correction application has been in use since 2019
 - ORM method with measurement-based beam response
 - LS1 CB05 to 06 were tuned in about 30 minutes in September 2019
 - » Spent most of time to measure BPM response to upstream corrector change
- Implemented model-based trajectory correction application in 2021
 - Calculate response matrix by envelope code FLAME
 - Applied to tune several cryomodules in a few minutes
- This application will be upgraded to series of tuning for the entire LS by one knob

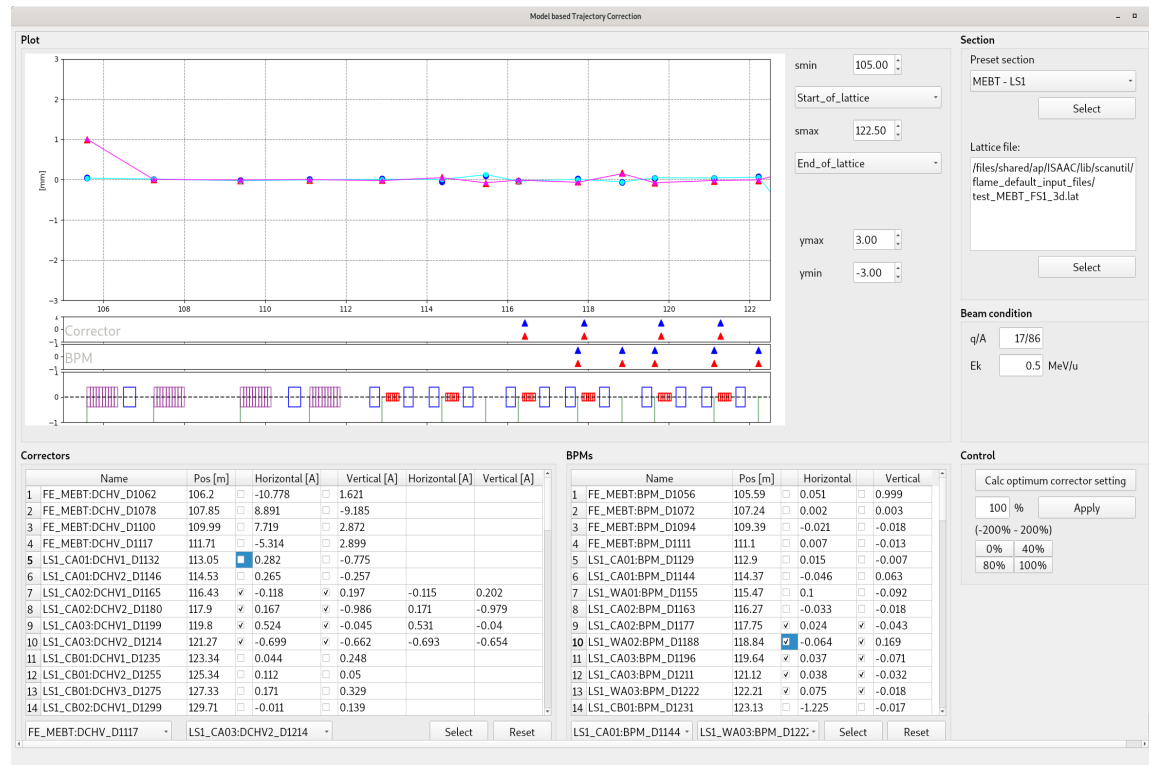

Model-Based Beam Central Trajectory Correction

- There are 144 BPMs in the FRIB linac to measure beam positions
 - Renewal frequency is 5 Hz
- Typical reading of BPMs: beam positions in X and Y, and signal magnitude

